

■ **EK** 系列 / 凸形固定側

訂購編號 Order Coding	型號 Model No.	表面處理 Surface treatment	適用螺桿 Applicable ballscrew accuracy grade	使用軸承 Bearing
EK05_C7	EK05	染黑 Black Oxide	C7	605
EK05_C7N		化學鍍 Electyolless Nickel Plating	C7	605
EK06_C7	EK06	染黑 Black Oxide	C7	606
EK06_C5			C5	706A P0
EK06_C3			C3	706A P5
EK06_C7N		化學鍍 Electyolless Nickel Plating	C7	606
EK06_C5N			C5	706A P0
EK06_C3N			C3	706A P5
EK08_C7	EK08	染黑 Black Oxide	C7	608
EK08_C5			C5	708A P0
EK08_C3			C3	708A P5
EK08_C7N		化學鍍 Electyolless Nickel Plating	C7	608
EK08_C5N			C5	708A P0
EK08_C3N			C3	708A P5
EK10_C7	EK10	染黑 Black Oxide	C7	7000A P0
EK10_C5			C5	
EK10_C3			C3	7000A P5
EK10_C7N		化學鍍 Electyolless Nickel Plating	C7	7000A P0
EK10_C5N			C5	7000A P0
EK10_C3N			C3	7000A P5
EK12_C7	EK12	染黑 Black Oxide	C7	7001A P0
EK12_C5			C5	7001A P5
EK12_C3			C3	7001A P5
EK12_C7N		化學鍍 Electyolless Nickel Plating	C7	7001A P0
EK12_C5N			C5	7001A P0
EK12_C3N			C3	7001A P5
EK15_C7	EK15	染黑 Black Oxide	C7	7002A P0
EK15_C5			C5	7002A P5
EK15_C3			C3	7002A P5
EK15_C7N		化學鍍 Electyolless Nickel Plating	C7	7002A P0
EK15_C5N			C5	7002A P0
EK15_C3N			C3	7002A P5
EK20_C7	EK20	染黑 Black Oxide	C7	7204A P0
EK20B_C7			C7	7204B P0
EK20_C5			C5	7204A P0
EK20B_C5			C5	7204B P0
EK20_C3			C3	7204A P5
EK20_C7N			化學鍍 Electyolless Nickel Plating	C7
EK20B_C7N		C7		7204B P0
EK20_C5N		C5		7204A P0
EK20B_C5N		C5		7204B P0
EK20_C3N		C3		7204A P5

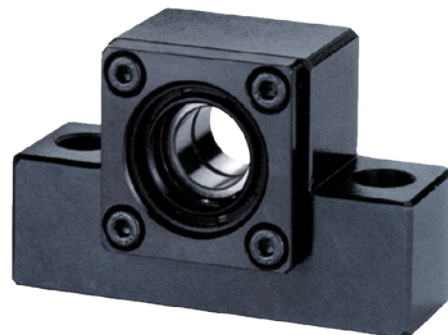

染黑 (適用環境一般)

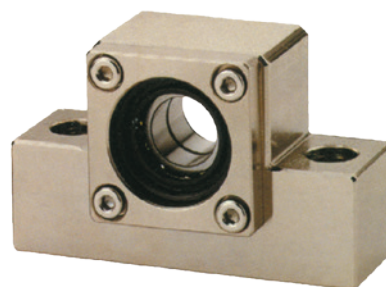

化學鍍 (適用無塵室環境)

- C7 級使用之軸承無預壓處理，軸向最大間隙 0.018mm
Bearings are no Preload for C7 type support units, and Max. Axial clearance is 0.018mm
- C5 級使用之軸承經預壓處理，軸向 0mm 間隙。
Bearings make Preload for C5 type support units, and Axial clearance is 0mm.
- 軸承皆採用 日系品牌大廠。
All of bearings Use Japan's brand bearings.

■ **EK** 系列 / 凸形固定側

EK05

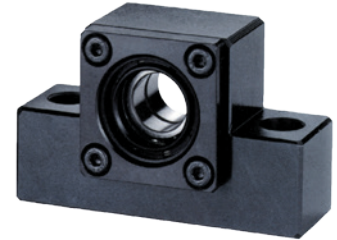
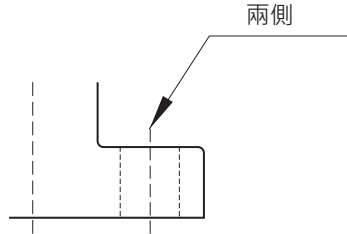

EK06, EK08

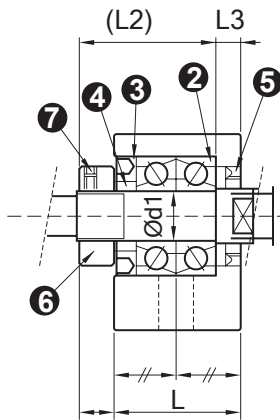
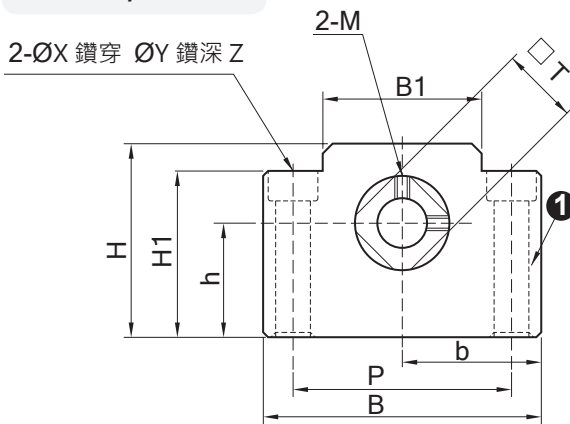

EK10~EK20

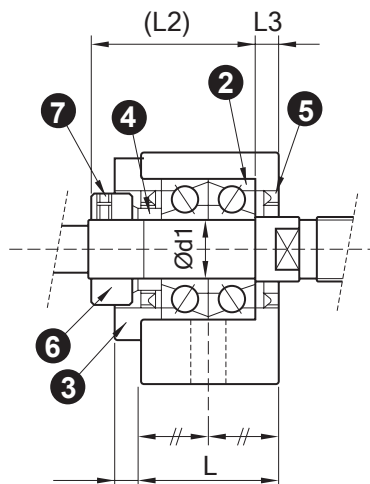
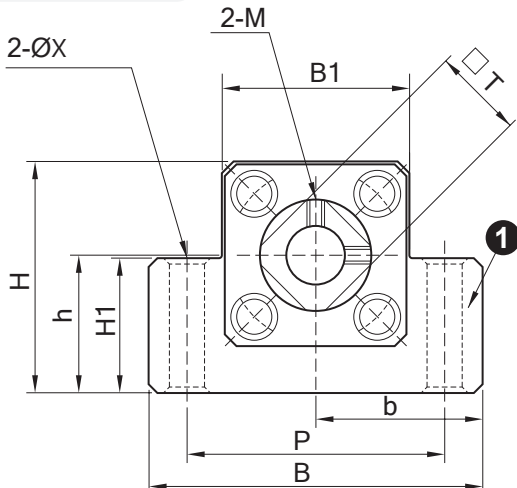

編號 Part No.	部品名稱 Part name	數量 Qty
1	軸承座主體	1
2	軸承	1組
3	壓板	1
4	間隔圈	2
5	軸封	1(2)
6	鎖固螺帽	1
7	內六角止付螺絲附銅片	2

單位/Unit : mm

型號	d1	L	L1	L2	L3	B	H	b		B1	H1	P	X	Y	Z	M	T
								+0.02	+0.02								
EK05	5	16.5	5.5	18.5	3.5	26	21	18	11	20	8	28	4.5	-	-	M3	11
EK06	6	20	5.5	22	3.5	42	25	21	13	18	20	30	5.5	9.5	11	M3	12
EK08	8	23	7	26	4	52	32	36	17	25	26	38	6.6	11	12	M3	14
EK10	10	24	6	29.5	6	70	43	35	25	36	24	52	9	-	-	M3	16
EK12	12	24	6	29.5	6	70	43	35	25	36	24	52	9	-	-	M4	19
EK15	15	25	6	36	5	80	49	40	30	41	25	60	11	-	-	M4	22
EK20	20	42	10	50	10	95	58	47.5	30	56	25	75	11	-	-	M4	30

EF 系列 / 凸形支撐側

訂購編號 Order Coding	型號 Model No.	表面處理 Surface treatment	適用螺桿 Applicable ballscrew accuracy grade	使用軸承 Bearing
EF06_C7	EF06	染黑 Black Oxide	C7	606ZZ
EF06_C3			C3	606ZZ
EF06_C7N		化學鍍 Electyless Nickel Plating	C7	606VV
EF06_C3N			C3	606VV
EF08_C7	EF08	染黑 Black Oxide	C7	606ZZ
EF08_C3			C3	606ZZ
EF08_C7N		化學鍍 Electyless Nickel Plating	C7	606VV
EF08_C3N			C3	606VV
EF10_C7	EF10	染黑 Black Oxide	C7	608ZZ
EF10_C3			C3	608ZZ
EF10_C7N		化學鍍 Electyless Nickel Plating	C7	608DD
EF10_C3N			C3	608DD
EF12_C7	EF12	染黑 Black Oxide	C7	6000ZZ
EF12_C3			C3	6000ZZ
EF12_C7N		化學鍍 Electyless Nickel Plating	C7	6000DDU
EF12_C3N			C3	6000DDU
EF15_C7	EF15	染黑 Black Oxide	C7	6002ZZ
EF15_C3			C3	6002ZZ
EF15_C7N		化學鍍 Electyless Nickel Plating	C7	6002DDU
EF15_C3N			C3	6002DDU
EF20_C7	EF20	染黑 Black Oxide	C7	6204ZZ
EF20_C3			C3	6204ZZ
EF20_C7N		化學鍍 Electyless Nickel Plating	C7	6204DDU
EF20_C3N			C3	6204DDU



染黑 (適用環境一般)

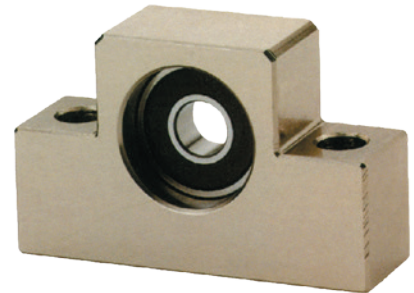

化學鍍 (適用無塵室環境)

1. 染黑使用之軸承採用雙鐵蓋。
It is used double pressed steel cages for Black Oxide type support units.
2. 化學鍍使用之軸承採用雙塑膠蓋。
It is used double plastic cages for Electroless Nickel Plating type support units.
3. 軸承皆採用 日系品牌大廠。
All of bearings Use Japan's brand bearings.

2-ØX 鑽穿 ØY 鑽深 Z

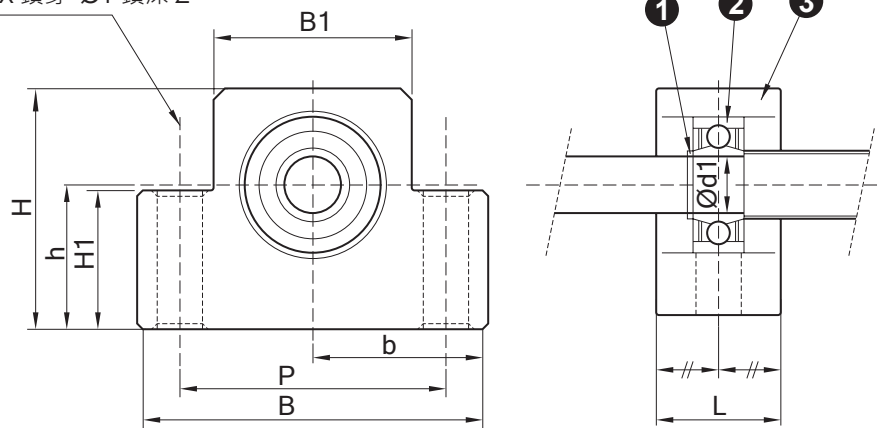

編號 Part No.	部品名稱 Part name	數量 Qty
1	軸承座主體	1
2	軸承	1 組
3	C型扣環	1

單位/Unit : mm

型號	d1	L	B	H	b	h	B1	H1	P	X	Y	Z	使用軸承	使用 C型扣環
					+0.02	+0.02								
EF06	6	12	42	25	21	13	18	20	30	5.5	9.5	11	606ZZ	S 06
EF08	6	14	52	32	36	17	25	26	38	6.6	11	12	606ZZ	S 06
EF10	8	20	70	43	35	25	36	24	52	9	-	-	608ZZ	S 08
EF12	10	20	70	43	35	25	36	24	52	9	-	-	6000ZZ	S 10
EF15	15	20	80	49	40	30	41	25	60	11	-	-	6002ZZ	S 15
EF20	20	26	95	58	47.5	30	56	25	75	11	-	-	6204ZZ	S 20

■ **BK** 系列 / 方形固定側

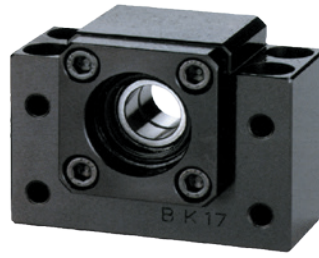

染黑 (適用環境一般)

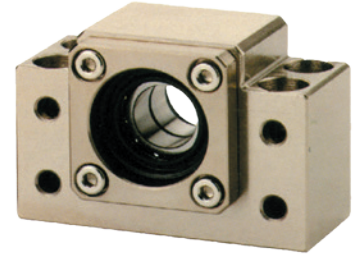

化學鍍 (適用無塵室環境)

訂購編號 Order Coding	型號 Model No.	表面處理 Surface treatment	適用螺桿 Applicable ballscrew accuracy grade	使用軸承 Bearing
BK10_C7	BK10	染黑 Black Oxide	C7	7000A P0
BK10_C5			C5	
BK10_C3			C3	
BK10_C7N		化學鍍 Electyless Nickel Plating	C7	7000A P0
BK10_C5N			C5	
BK10_C3N			C3	
BK12_C7	BK12	染黑 Black Oxide	C7	7001A P0
BK12_C5			C5	
BK12_C3			C3	
BK12_C7N		化學鍍 Electyless Nickel Plating	C7	7001A P0
BK12_C5N			C5	
BK12_C3N			C3	
BK15_C7	BK15	染黑 Black Oxide	C7	7002A P0
BK15_C5			C5	
BK15_C3			C3	
BK15_C7N		化學鍍 Electyless Nickel Plating	C7	7002A P0
BK15_C5N			C5	
BK15_C3N			C3	
BK17_C7	BK17	染黑 Black Oxide	C7	7203A P0
BK17_C5			C5	
BK17_C3			C3	
BK17_C7N		化學鍍 Electyless Nickel Plating	C7	7203A P0
BK17_C5N			C5	
BK17_C3N			C3	
BK20_C7	BK20	染黑 Black Oxide	C7	7004A P0
BK20_C5			C5	
BK20_C3			C3	
BK20_C7N		化學鍍 Electyless Nickel Plating	C7	7004A P0
BK20_C5N			C5	
BK20_C3N			C3	

訂購編號 Order Coding	型號 Model No.	表面處理 Surface treatment	適用螺桿 Applicable ballscrew accuracy grade	使用軸承 Bearing	
BK25_C7	BK25	染黑 Black Oxide	C7	7205A P0	
BK25B_C7			C7	7205B P0	
BK25_C5			C5	7205A P0	
BK25B_C5			C5	7205B P0	
BK25_C3			C3	7205A P5	
BK25_C7N			化學鍍 Electyless Nickel Plating	C7	7205A P0
BK25B_C7N	C7	7205B P0			
BK25_C5N	C5	7205A P0			
BK25B_C5N	C5	7205B P0			
BK25_C3N	C3	7205A P5			
BK30_C7	BK30	染黑 Black Oxide		C7	7206A P0
BK30B_C7			C7	7206B P0	
BK30_C5			C5	7206A P0	
BK30B_C5			C5	7206B P0	
BK30_C3			C3	7206A P5	
BK30_C7N			化學鍍 Electyless Nickel Plating	C7	7206A P0
BK30B_C7N	C7	7206B P0			
BK30_C5N	C5	7206A P0			
BK30B_C5N	C5	7206B P0			
BK30_C3N	C3	7206A P5			
BK35_C7	BK35	染黑 Black Oxide		C7	7207B P0
BK35_C5			C5	7207B P0	
BK35_C3			C3	7207B P5	
BK35_C7N			化學鍍 Electyless Nickel Plating	C7	7207B P0
BK35_C5N				C5	7207B P0
BK35_C3N				C3	7207B P5
BK40_C7	BK40	染黑 Black Oxide	C7	7208B P0	
BK40_C5			C5	7208B P0	
BK40_C3			C3	7208B P5	
BK40_C7N			化學鍍 Electyless Nickel Plating	C7	7208B P0
BK40_C5N				C5	7208B P0
BK40_C3N				C3	7208B P5

- C7 級使用之軸承無預壓處理 · 軸向最大間隙 0.018mm
Bearings are no Preload for C7 type support units, and Max. Axial clearance is 0.018mm
- C5 級使用之軸承經預壓處理 · 軸向 0mm 間隙。
Bearings make Preload for C5 type support units, and Axial clearance is 0mm.
- 軸承皆採用 日系品牌大廠。
All of bearings Use Japan's brand bearings.

■ **BK** 系列 / 方形固定側

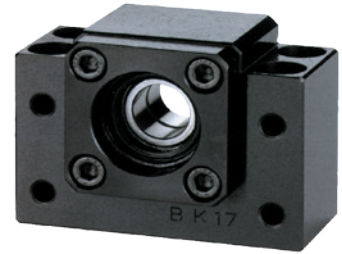

編號 Part No.	部品名稱 Part name	數量 Qty
1	軸承座主體	1
2	軸承	1 組
3	壓板	1
4	間隔圈	2
5	軸封	2
6	鎖固螺帽	1 組
7	內六角止付螺絲附銅片	2

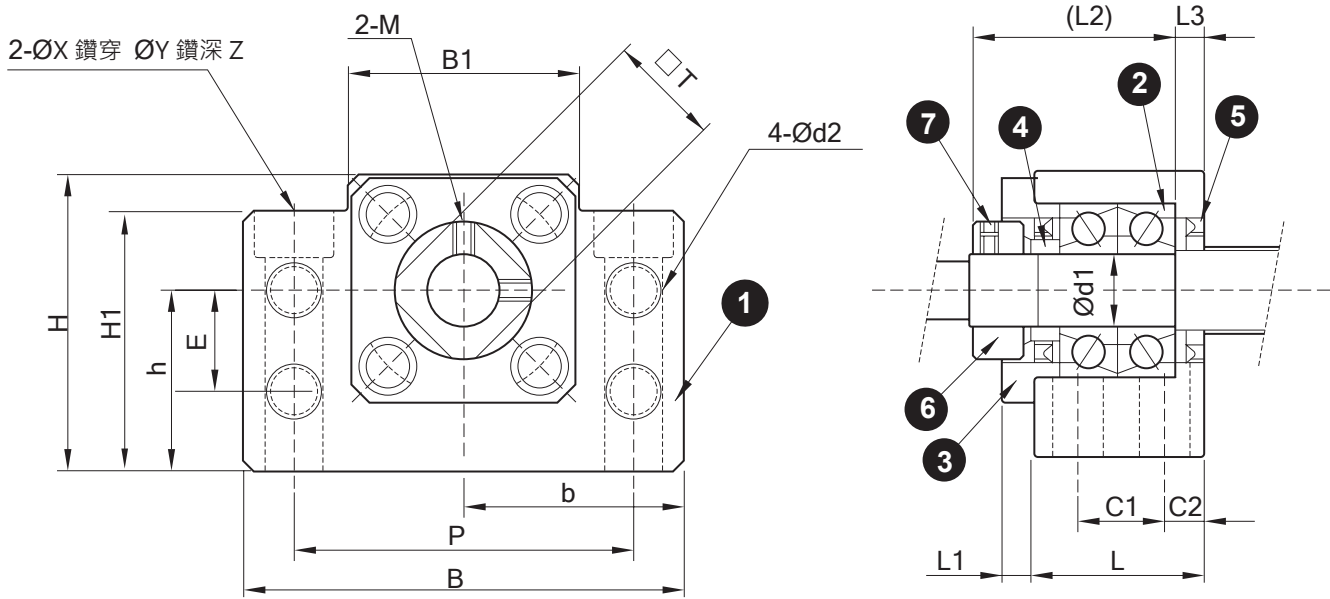

單位/Unit : mm

型號	d1	L	L1	L2	L3	B	H	b		h	B1	H1	E	P	C1	C2	d2	X	Y	Z	M	T
								+0.02	+0.02													
BK10	10	25	5	29	5	60	39	30	22	34	32.5	15	46	13	6	5.5	6.6	10.8	5	M3	16	
BK12	12	25	5	29	5	60	43	30	25	34	32.5	18	46	13	6	5.5	6.6	10.8	1.5	M4	19	
BK15	15	27	6	32	6	70	48	35	28	40	38	18	54	15	6	5.5	6.6	11	6.5	M4	22	
BK17	17	35	9	44	7	86	64	43	39	50	55	28	68	19	8	6.6	9	14	8.5	M4	24	
BK20	20	35	8	43	8	88	60	44	34	52	50	22	70	19	8	6.6	9	14	8.5	M4	30	
BK25	25	42	12	54	9	106	80	53	48	64	70	33	85	22	10	9	11	17.5	11	M5	35	
BK30	30	45	14	61	9	128	89	64	51	76	78	33	102	23	11	11	14	20	13	M6	40	
BK35	35	50	14	67	12	140	96	70	52	88	79	35	114	26	12	11	14	20	13	M8	50	
BK40	40	61	18	76	15	160	110	80	60	100	90	37	130	33	14	14	18	26	17.5	M8	50	

■ BF 系列 / 方形支撐側

訂購編號 Order Coding	型號 Model No.	表面處理 Surface treatment	適用螺桿 Applicable ballscrew accuracy grade	使用軸承 Bearing
BF10_C7	BF10	染黑 Black Oxide	C7	608ZZ
BF10_C3			C3	608ZZ
BF10_C7N		化學鍍 Electyless Nickel Plating	C7	608VV
BF10_C3N			C3	608VV
BF12_C7	BF12	染黑 Black Oxide	C7	6000ZZ
BF12_C3			C3	6000ZZ
BF12_C7N		化學鍍 Electyless Nickel Plating	C7	6000VV
BF12_C3N			C3	6000VV
BF15_C7	BF15	染黑 Black Oxide	C7	6002ZZ
BF15_C3			C3	6002ZZ
BF15_C7N		化學鍍 Electyless Nickel Plating	C7	6002VV
BF15_C3N			C3	6002VV
BF17_C7	BF17	染黑 Black Oxide	C7	6203ZZ
BF17_C3			C3	6203ZZ
BF17_C7N		化學鍍 Electyless Nickel Plating	C7	6203VV
BF17_C3N			C3	6203VV
BF20_C7	BF20	染黑 Black Oxide	C7	6004ZZ
BF20_C3			C3	6004ZZ
BF20_C7N		化學鍍 Electyless Nickel Plating	C7	6004VV
BF20_C3N			C3	6004VV
BF25_C7	BF25	染黑 Black Oxide	C7	6205ZZ
BF25_C3			C3	6205ZZ
BF25_C7N		化學鍍 Electyless Nickel Plating	C7	6205VV
BF25_C3N			C3	6205VV
BF30_C7	BF30	染黑 Black Oxide	C7	6206ZZ
BF30_C3			C3	6206ZZ
BF30_C7N		化學鍍 Electyless Nickel Plating	C7	6206VV
BF30_C3N			C3	6206VV
BF35_C7	BF35	染黑 Black Oxide	C7	6207ZZ
BF35_C3			C3	6207ZZ
BF35_C7N		化學鍍 Electyless Nickel Plating	C7	6207VV
BF35_C3N			C3	6207VV
BF40_C7	BF40	染黑 Black Oxide	C7	6208ZZ
BF40_C3			C3	6208ZZ
BF40_C7N		化學鍍 Electyless Nickel Plating	C7	6208VV
BF40_C3N			C3	6208VV

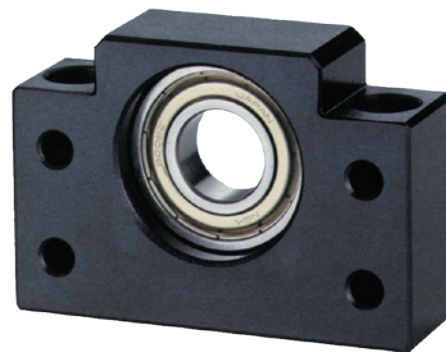

染黑 (適用環境一般)

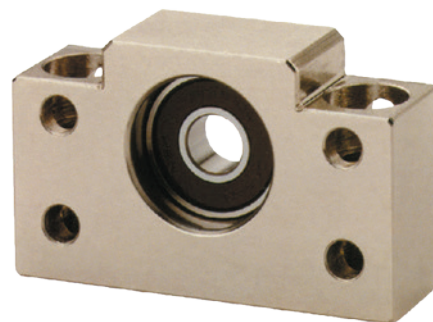

化學鍍 (適用無塵室環境)

1. 染黑使用之軸承採用雙鐵蓋。

It is used double pressed steel cages for Black Oxide type support units.

2. 化學鍍使用之軸承採用雙塑膠蓋。

It is used double plastic cages for Electroless Nickel Plating type support units.

3. 軸承皆採用 日系品牌大廠。

All of bearings Use Japan's brand bearings.

■ **BF** 系列 / 方形支撐側

編號 Part No.	部品名稱 Part name	數量 Qty
1	軸承座主體	1
2	軸承	1 組
3	C型扣環	1

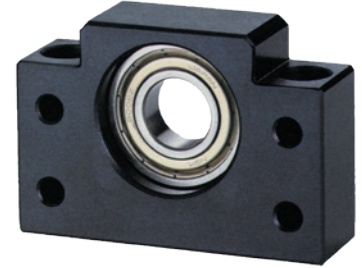

2-ØX 鑽穿 ØY 鑽深 Z

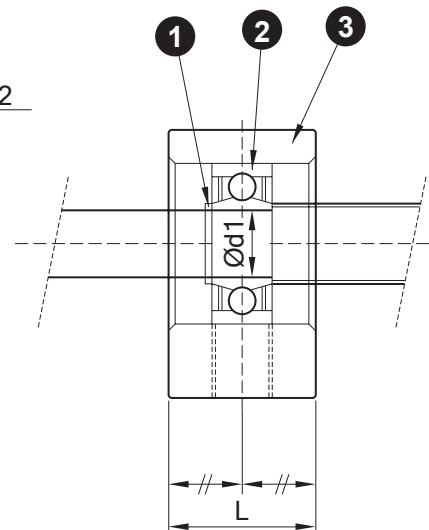
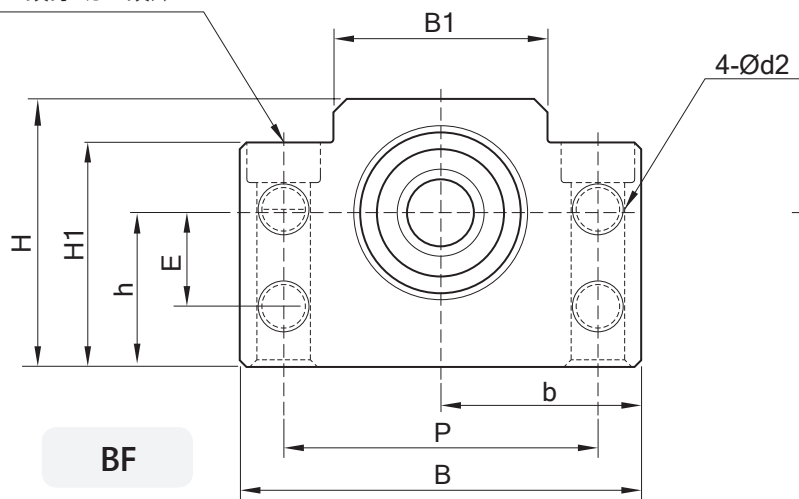

單位/Unit : mm

型號	d1	L	B	H	b	h	B1	H1	E	P	d2	X	Y	Z	使用軸承	使用 C型扣環
					+0.02	+0.02										
BF10	8	20	60	39	30	22	34	32.5	15	46	5.5	6.6	10.8	5	608ZZ	S 08
BF12	10	20	60	43	30	25	34	32.5	18	46	5.5	6.6	10.8	1.5	6000ZZ	S 10
BF15	15	20	70	48	35	28	40	38	18	54	5.5	6.6	11	6.5	6002ZZ	S 15
BF17	17	23	86	64	43	39	50	55	28	68	6.6	9	14	8.5	6203ZZ	S 17
BF20	20	26	88	60	44	34	52	50	22	70	6.6	9	14	8.5	6004ZZ	S 20
BF25	25	30	106	80	53	48	64	70	33	85	9	11	17.5	11	6205ZZ	S 25
BF30	30	32	128	89	64	51	76	78	33	102	11	14	20	13	6206ZZ	S 30
BF35	35	32	140	96	70	52	88	79	35	114	11	14	20	13	6207ZZ	S 35
BF40	40	37	160	110	80	60	100	90	37	130	14	18	26	17.5	6208ZZ	S 40

■ **FK** 系列 / 圓形固定側



染黑 (適用環境一般)



化學鍍 (適用無塵室環境)

訂購編號 Order Coding	型號 Model No.	表面處理 Surface treatment	適用螺桿 Applicable ballscrew accuracy grade	使用軸承 Bearing	訂購編號 Order Coding	型號 Model No.	表面處理 Surface treatment	適用螺桿 Applicable ballscrew accuracy grade	使用軸承 Bearing
FK05_C7	FK05	染黑 Black Oxide	C7	605	FK17_C7	FK17	染黑 Black Oxide	C7	7203A P0
FK05_C7N		化學鍍 Electyless Nickel Plating	C7	605	FK17_C5			C5	7203A P0
FK06_C7	FK06	染黑 Black Oxide	C7	606	FK17_C3			C3	7203A P5
FK06_C5			C5	706A P0	FK17_C7N		C7	7203A P0	
FK06_C3			C3	706A P5	FK17_C5N		C5	7203A P0	
FK06_C7N		化學鍍 Electyless Nickel Plating	C7	606	FK17_C3N	C3	7203A P5		
FK06_C5N			C5	706A P0	FK20_C7	C7	7204A P0		
FK06_C3N			C3	706A P5	FK20B_C7	C7	7204B P0		
FK08_C7	FK08	染黑 Black Oxide	C7	608	FK20_C5	FK20	染黑 Black Oxide	C5	7204A P0
FK08_C5			C5	708A P0	FK20B_C5			C5	7204B P0
FK08_C3			C3	708A P5	FK20_C3			C3	7204A P5
FK08_C7N		化學鍍 Electyless Nickel Plating	C7	608	FK20_C7N		C7	7204A P0	
FK08_C5N			C5	708A P0	FK20B_C7N		C7	7204B P0	
FK08_C3N			C3	708A P5	FK20_C5N	C5	7204A P0		
FK10_C7	FK10	染黑 Black Oxide	C7	7000A P0	FK20B_C5N	FK25	染黑 Black Oxide	C5	7204B P0
FK10_C5			C5	7000A P0	FK25_C7			C7	7205A P0
FK10_C3			C3	7000A P5	FK25B_C7			C7	7205B P0
FK10_C7N		化學鍍 Electyless Nickel Plating	C7	7000A P0	FK25_C5		C5	7205A P0	
FK10_C5N			C5	7000A P0	FK25B_C5		C5	7205B P0	
FK10_C3N			C3	7000A P5	FK25_C3	C3	7205A P5		
FK12_C7	FK12	染黑 Black Oxide	C7	7001A P0	FK25_C7N	FK30	染黑 Black Oxide	C7	7205A P0
FK12_C5			C5	7001A P0	FK25B_C7N			C7	7205B P0
FK12_C3			C3	7001A P5	FK25_C5N			C5	7205A P0
FK12_C7N		化學鍍 Electyless Nickel Plating	C7	7001A P0	FK25B_C5N		C5	7205B P0	
FK12_C5N			C5	7001A P0	FK25_C3N		C3	7205A P5	
FK12_C3N			C3	7001A P5	FK30_C7	C7	7206A P0		
FK15_C7	FK15	染黑 Black Oxide	C7	7002A P0	FK30B_C7	FK30	染黑 Black Oxide	C7	7206B P0
FK15_C5			C5	7002A P0	FK30_C5			C5	7206A P0
FK15_C3			C3	7002A P5	FK30B_C5			C5	7206B P0
FK15_C7N		化學鍍 Electyless Nickel Plating	C7	7002A P0	FK30_C3		C3	7206A P5	
FK15_C5N			C5	7002A P0	FK30_C7N		C7	7206A P0	
FK15_C3N			C3	7002A P5	FK30B_C7N	C7	7206B P0		
				FK30_C5N	C5	7206A P0			
				FK30B_C5N	C5	7206B P0			
				FK30_C3N	C3	7206A P5			

- C7 級使用之軸承無預壓處理 · 軸向最大間隙 0.018mm
Bearings are no Preload for C7 type support units, and Max. Axial clearance is 0.018mm
- C5 級使用之軸承經預壓處理 · 軸向 0mm 間隙。
Bearings make Preload for C5 type support units, and Axial clearance is 0mm.
- 軸承皆採用日系品牌大廠。
All of bearings Use Japan's brand bearings.

■ **FK** 系列 / 圓形固定側



編號 Part No.	部品名稱 Part name	數量 Qty
1	軸承座主體	1
2	軸承	1 組
3	壓板	1
4	間隔圈	2
5	軸封	2
6	鎖固螺帽	1 組
7	內六角止付螺絲附銅片	2

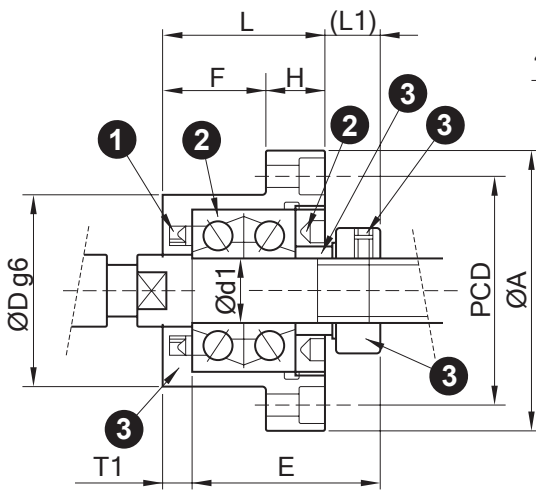

安裝方法 A

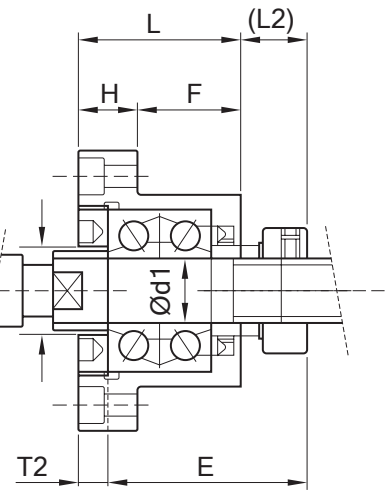
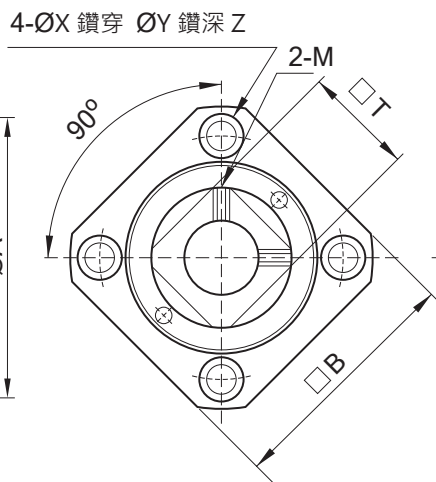

安裝方法 B

單位/Unit : mm

型號	d1	L	H	F	E	Dg6	A	PCD	B	裝置方法 A		裝置方法 B		X	Y	Z	M	T	
										L1	T1	L2	T2						
FK05	5	16.5	6	10.5	18.5	20	-0.007 -0.02	34	26	26	5.5	3.5	7	5	3.4	6.5	4	M3	11
FK06	6	20	7	13	22	22	-0.007 -0.02	36	28	28	5.5	3.5	8.5	6.5	3.4	6.5	4	M3	12
FK08	8	23	9	14	26	28	-0.007 -0.02	43	35	35	7	4	10	7	3.4	6.5	4	M3	14

單位/Unit : mm

型號	d1	L	H	F	E	Dg6	A	PCD	B	裝置方法 A		裝置方法 B		X	Y	Z	M	T	
										L1	T1	L2	T2						
FK10	10	27	10	17	29.5	34	-0.009 -0.025	52	42	42	7.5	5	8.5	6	4.5	8	4	M3	16
FK12	12	27	10	17	29.5	36	-0.009 -0.025	54	44	44	7.5	5	8.5	6	4.5	8	4	M4	19
FK15	15	32	15	17	36	40	-0.009 -0.025	63	50	52	10	6	12	8	5.5	9.5	6	M4	22
FK17	17	45	22	23	47	50	-0.009 -0.025	77	62	61	11	9	14	12	6.6	11	10	M4	24
FK20	20	52	22	30	50	57	-0.010 -0.029	85	70	68	8	10	12	14	6.6	11	10	M4	30
FK25	25	57	27	30	60	63	-0.010 -0.029	98	80	79	13	10	20	17	9	15	13	M5	35
FK30	30	62	30	32	61	75	-0.010 -0.029	117	95	93	11	12	17	18	11	17.5	15	M6	40

■ **FF** 系列 / 圓形支撐側

訂購編號 Order Coding	型號 Model No.	表面處理 Surface treatment	適用螺桿 Applicable ballscrew accuracy grade	使用軸承 Bearing
FF06_C7	FF06	染黑 Black Oxide	C7	606ZZ
FF06_C3			C3	606ZZ
FF06_C7N		化學鍍 Electyolless Nickel Plating	C7	606VV
FF06_C3N			C3	606VV
FF10_C7	FF10	染黑 Black Oxide	C7	608ZZ
FF10_C3			C3	608ZZ
FF10_C7N		化學鍍 Electyolless Nickel Plating	C7	608DD
FF10_C3N			C3	608DD
FF12_C7	FF12	染黑 Black Oxide	C7	6000ZZ
FF12_C3			C3	6000ZZ
FF12_C7N		化學鍍 Electyolless Nickel Plating	C7	6000DDU
FF12_C3N			C3	6000DDU
FF15_C7	FF15	染黑 Black Oxide	C7	6002ZZ
FF15_C3			C3	6002ZZ
FF15_C7N		化學鍍 Electyolless Nickel Plating	C7	6002DDU
FF15_C3N			C3	6002DDU
FF17_C7	FF17	染黑 Black Oxide	C7	6203ZZ
FF17_C3			C3	6203ZZ
FF17_C7N		化學鍍 Electyolless Nickel Plating	C7	6203DDU
FF17_C3N			C3	6203DDU
FF20_C7	FF20	染黑 Black Oxide	C7	6204ZZ
FF20_C3			C3	6204ZZ
FF20_C7N		化學鍍 Electyolless Nickel Plating	C7	6204DDU
FF20_C3N			C3	6204DDU
FF25_C7	FF25	染黑 Black Oxide	C7	6205ZZ
FF25_C3			C3	6205ZZ
FF25_C7N		化學鍍 Electyolless Nickel Plating	C7	6205DDU
FF25_C3N			C3	6205DDU
FF30_C7	FF30	染黑 Black Oxide	C7	6206ZZ
FF30_C3			C3	6206ZZ
FF30_C7N		化學鍍 Electyolless Nickel Plating	C7	6206DDU
FF30_C3N			C3	6206DDU



染黑 (適用環境一般)

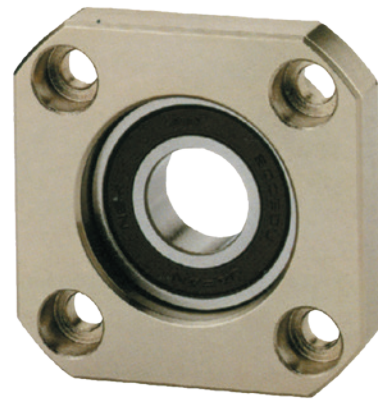

化學鍍 (適用無塵室環境)

1. 染黑使用之軸承採用雙鐵蓋。
It is used double pressed steel cages for Black Oxide type support units.
2. 化學鍍使用之軸承採用雙塑膠蓋。
It is used double plastic cages for Electroless Nickel Plating type support units.
3. 軸承皆採用 日系品牌大廠。
All of bearings Use Japan's brand bearings.

■ **FF** 系列 / 圓形支撐側



編號 Part No.	部品名稱 Part name	數量 Qty
1	軸承座主體	1
2	軸承	1 組
3	C型扣環	1

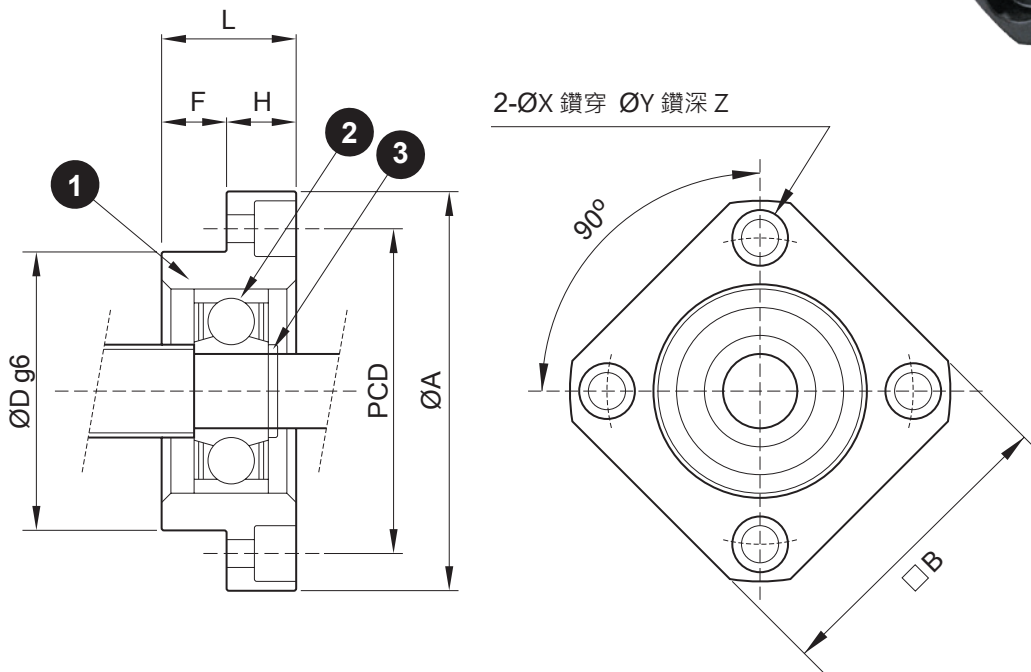

單位/Unit : mm

型號	d1	L	H	F	Dg6	A	PCD	B	X	Y	Z	使用軸承	使用C型扣環
FF06	6	10	6	4	22 -0.007 -0.02	36	28	28	3.4	6.5	4	606ZZ	S 06
FF10	8	12	7	5	28 -0.007 -0.02	43	35	35	3.4	6.5	4	608ZZ	S 08
FF12	10	15	7	8	34 -0.009 -0.025	52	42	42	4.5	8	4	6000ZZ	S 10
FF15	15	17	9	8	40 -0.009 -0.025	63	50	52	5.5	9.5	5.5	6002ZZ	S 15
FF17	17	20	11	9	50 -0.009 -0.025	77	62	61	6.6	11	6.5	6203ZZ	S 17
FF20	20	20	11	9	57 -0.010 -0.029	85	70	68	6.6	11	6.5	6004ZZ	S 20
FF25	25	24	14	10	63 -0.010 -0.029	98	80	79	9	14	8.5	6205ZZ	S 25
FF30	30	27	18	9	75 -0.010 -0.029	117	95	93	11	17.5	11	6206ZZ	S 30

■ **AK** 系列 / 固定側

訂購編號 Order Coding	型號 Model No.	表面處理 Surface treatment	適用螺桿 Applicable ballscrew accuracy grade	使用軸承 Bearing
AK10_C7	AK10	染黑 Black Oxide	C7	7000A P0
AK10_C5			C5	7000A P5
AK10_C3			C3	7000A P5
AK10_C7N		化學鍍 Electyolless Nickel Plating	C7	7000A P0
AK10_C5N			C5	7000A P5
AK10_C3N			C3	7000A P5
AK12_C7	AK12	染黑 Black Oxide	C7	7001A P0
AK12_C5			C5	7001A P5
AK12_C3			C3	7001A P5
AK12_C7N		化學鍍 Electyolless Nickel Plating	C7	7001A P0
AK12_C5N			C5	7001A P5
AK12_C3N			C3	7001A P5
AK15_C7	AK15	染黑 Black Oxide	C7	7002A P0
AK15_C5			C5	7002A P5
AK15_C3			C3	7002A P5
AK15_C7N		化學鍍 Electyolless Nickel Plating	C7	7002A P0
AK15_C5N			C5	7002A P5
AK15_C3N			C3	7002A P5
AK20_C7	AK20	染黑 Black Oxide	C7	7204A P0
AK20B_C7			C7	7204B P0
AK20_C5			C5	7204A P0
AK20B_C5			C5	7204B P0
AK20_C3			C3	7204A P5
AK20_C7N			化學鍍 Electyolless Nickel Plating	C7
AK20B_C7N		C7		7204B P0
AK20_C5N		C5		7204A P0
AK20B_C5N		C5		7204B P0
AK20_C3N		C3		7204A P5
AK20_C3N		C3		7204A P5

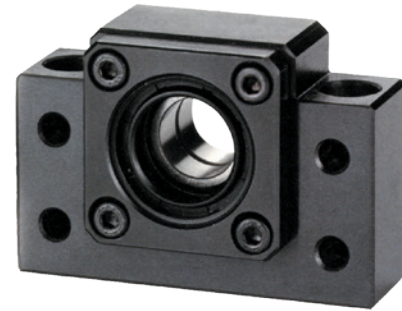

染黑 (適用環境一般)

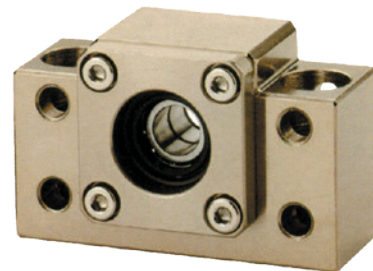

化學鍍 (適用無塵室環境)

- C7 級使用之軸承無預壓處理 · 軸向最大間隙 0.018mm
Bearings are no Preload for C7 type support units, and Max. Axial clearance is 0.018mm
- C5 級使用之軸承經預壓處理 · 軸向 0mm 間隙。
Bearings make Preload for C5 type support units, and Axial clearance is 0mm.
- 軸承皆採用 日系品牌大廠。
All of bearings Use Japan's brand bearings.

■ **AK** 系列 / 固定側

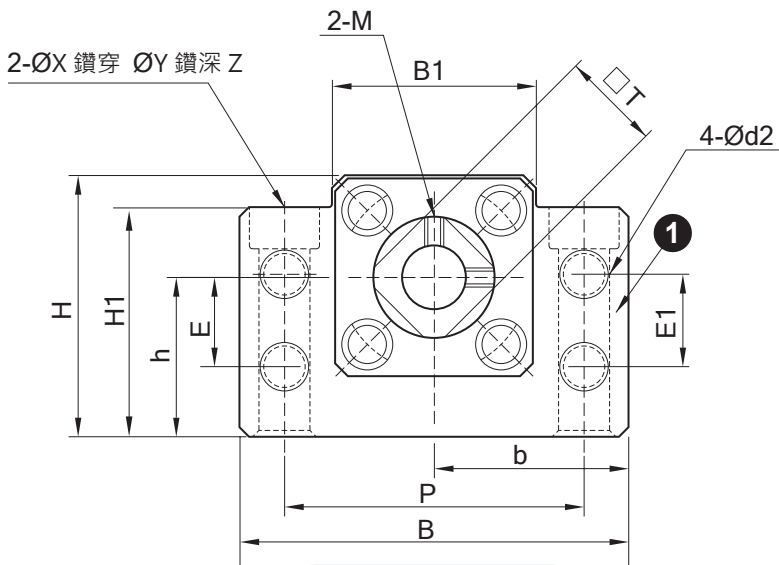
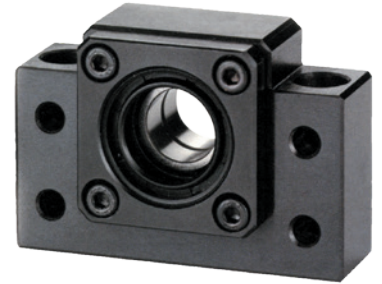

AK10~AK20

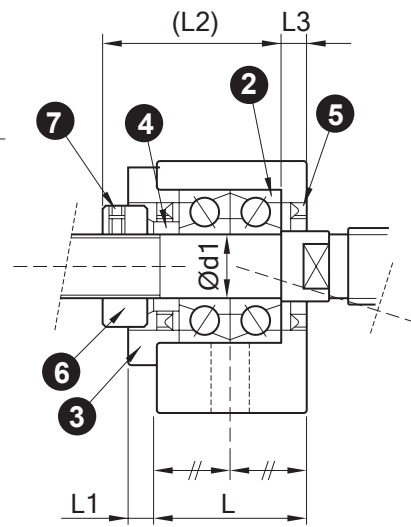

AK10~AK25

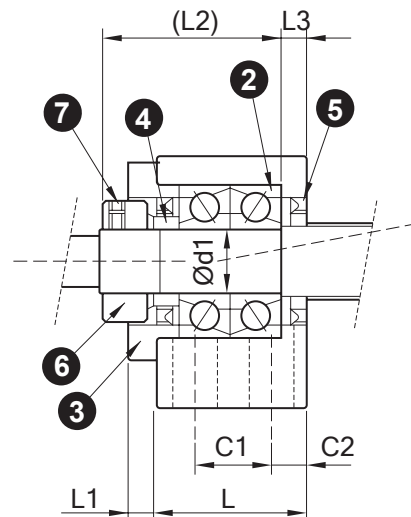

AK20

編號 Part No.	部品名稱 Part name	數量 Qty
1	軸承座主體	1
2	軸承	1 組
3	壓板	1
4	間隔圈	2
5	軸封	2
6	鎖固螺帽	1 組
7	內六角止付螺絲附銅片	2

單位/Unit : mm

型號	d1	L	L1	L2	L3	B	H	b		B1	H1	E1	P	d2	X	Y	Z	M	T	E	C1	C2
								+0.02	+0.02													
AK10	10	24	6	29.5	6	70	43	35	25	36	35	19	52	6.5	9	14	11	M3	16	15	-	-
AK12	12	24	6	29.5	6	70	43	35	25	36	35	19	52	6.5	9	14	11	M4	19	15	-	-
AK15	15	25	6	36	5	80	49	40	30	41	40	19	60	6.5	11	17	15	M4	22	15	-	-
AK17	20	42	10	50	10	95	58	47.5	30	56	45	19	75	6.5	11	17	15	M4	30	15	22	10

■ **AF** 系列 / 支撐側

訂購編號 Order Coding	型號 Model No.	表面處理 Surface treatment	適用螺桿 Applicable ballscrew accuracy grade	使用軸承 Bearing
AF10_C7	AF10	染黑 Black Oxide	C7	608ZZ
AF10_C3			C3	608ZZ
AF10_C7N		化學鍍 Electyless Nickel Plating	C7	608DD
AF10_C3N			C3	608DD
AF12_C7	AF12	染黑 Black Oxide	C7	6000ZZ
AF12_C3			C3	6000ZZ
AF12_C7N		化學鍍 Electyless Nickel Plating	C7	6000DDU
AF12_C3N			C3	6000DDU
AF15_C7	AF15	染黑 Black Oxide	C7	6002ZZ
AF15_C3			C3	6002ZZ
AF15_C7N		化學鍍 Electyless Nickel Plating	C7	6002DDU
AF15_C3N			C3	6002DDU
AF20_C7	AF20	染黑 Black Oxide	C7	6204ZZ
AF20_C3			C3	6204ZZ
AF20_C7N		化學鍍 Electyless Nickel Plating	C7	6204DDU
AF20_C3N			C3	6204DDU



染黑 (適用環境一般)

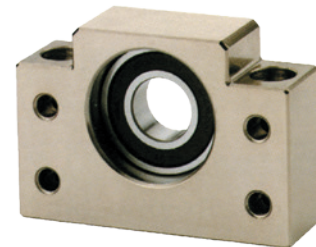

化學鍍 (適用無塵室環境)

1. 染黑使用之軸承採用雙鐵蓋。
It is used double pressed steel cages for Black Oxide type support units.
2. 化學鍍使用之軸承採用雙塑膠蓋。
It is used double plastic cages for Electroless Nickel Plating type support units.
3. 軸承皆採用 日系品牌大廠。
All of bearings Use Japan's brand bearings.

編號 Part No.	部品名稱 Part name	數量 Qty
1	軸承座主體	1
2	軸承	1 組
3	C型扣環	1

2-ØX 鑽穿 ØY 鑽深 Z

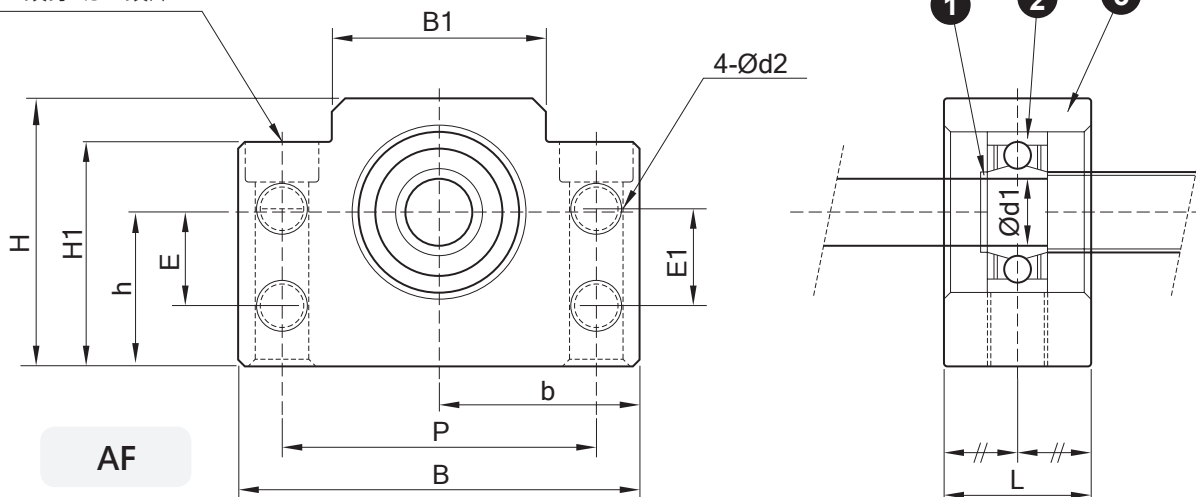

單位/Unit : mm

型號	d1	L	B	H	b		B1	H1	E1	P	d2	X	Y	Z	E	使用軸承	使用 C型扣環
					+0.02	+0.02											
BF10	8	20	60	43	35	25	36	35	19	52	6.5	9	14	11	15	608ZZ	S 08
BF12	10	20	60	43	35	25	36	35	19	52	6.5	9	14	11	15	6000ZZ	S 10
BF15	15	20	80	49	40	30	41	40	19	60	6.5	9	14	11	15	6002ZZ	S 15
BF20	20	26	95	58	47.5	30	56	45	19	75	6.5	11	17	15	15	6204ZZ	S 20

■ **WBK** 高荷重型

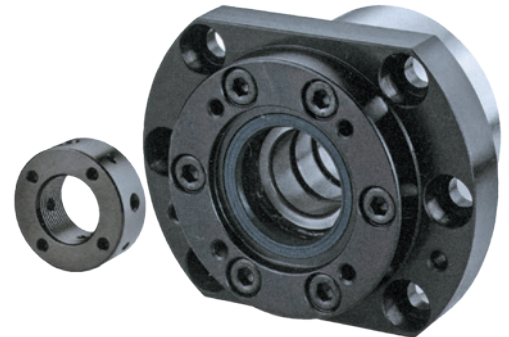

編號 Part No.	部品名稱 Part name	數量 Qty
1	軸承座主體	1
2	軸承	1組
3	壓板	1
4	間隔圈	2
5	軸封	2

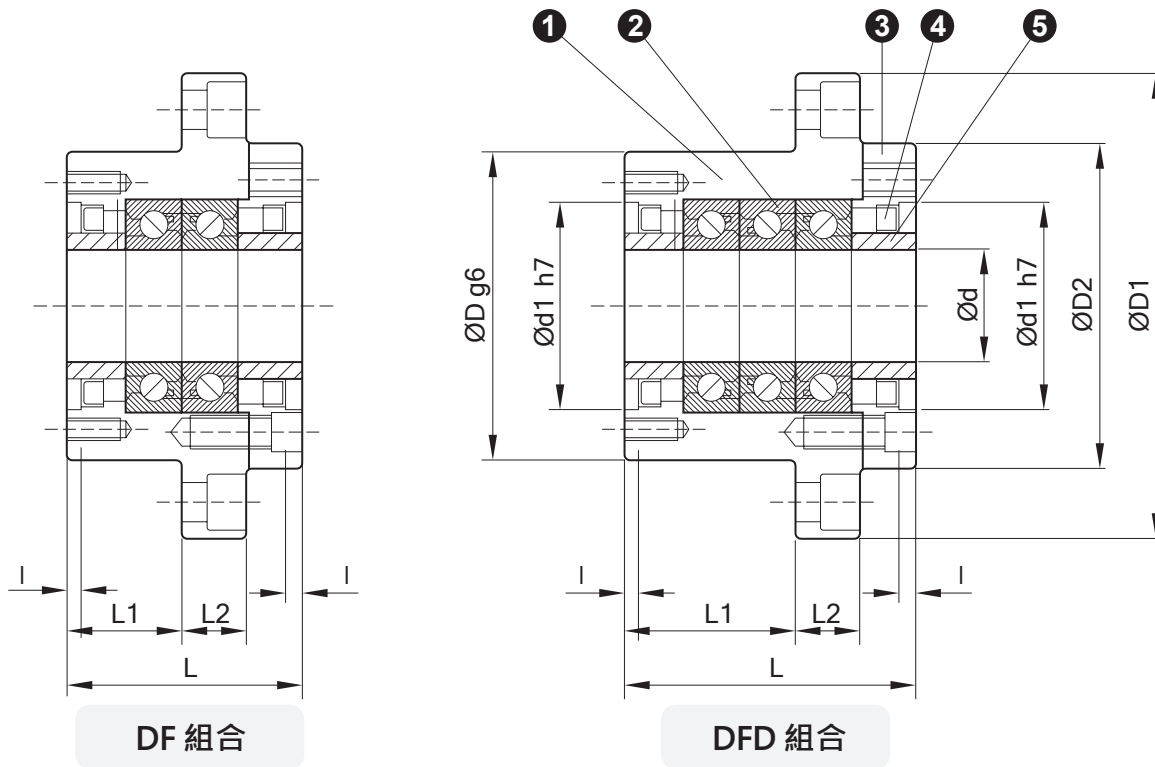

單位/Unit : mm

型號	d	D	D1	D2	L	L1	L2	A	W	X	Y	Z	d1	I	V	P	Q
WBK 17DF	17	70	106	72	60	32	15	80	88	9	14	8.5	45	3	58	M5	10
WBK 20DF	20	70	106	72	60	32	15	80	88	9	14	8.5	45	3	58	M5	10
WBK 25DF	25	85	130	90	66	33	18	100	110	11	17.5	11	57	4	70	M6	12
WBK 25DF	25	85	130	90	81	48	18	100	110	11	17.5	11	57	4	70	M6	12
WBK 30DF	30	85	130	90	66	33	18	100	110	11	17.5	11	57	4	70	M6	12
WBK 30DF	30	85	130	90	81	48	18	100	110	11	17.5	11	57	4	70	M6	12
WBK 35DF	35	95	142	102	66	33	18	106	121	11	17.5	11	69	4	80	M6	12
WBK 35DF	35	95	142	102	81	48	18	106	121	11	17.5	11	69	4	80	M6	12
WBK 40DF	40	95	142	102	66	33	18	106	121	11	17.5	11	69	4	80	M6	12
WBK 40DF	40	95	142	102	81	48	18	106	121	11	17.5	11	69	4	80	M6	12

■ **WBK** 高荷重型

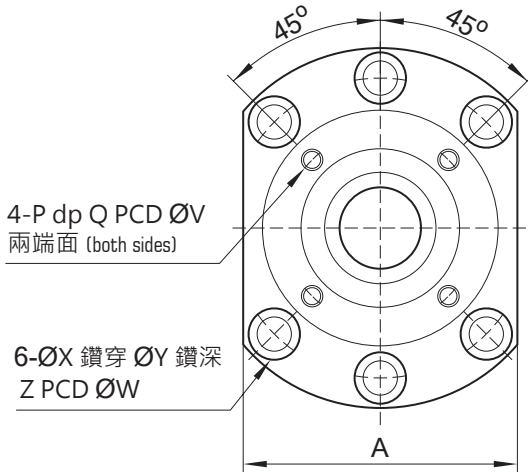
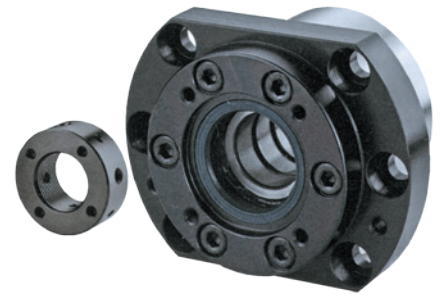

軸徑 Ød = 30
Shaft diameter

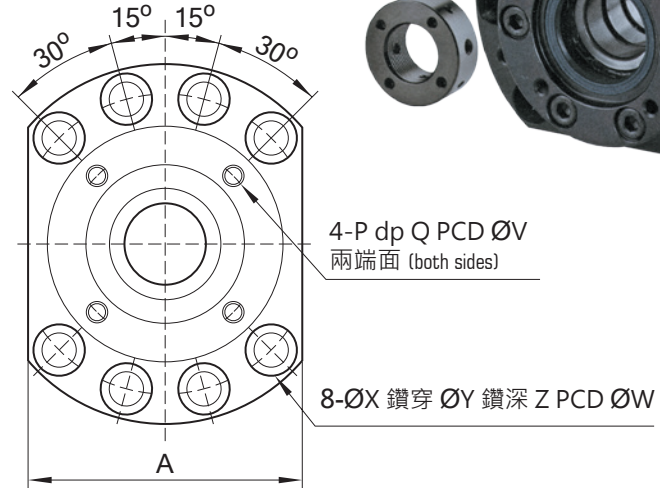

軸徑 Ød = 30
Shaft diameter

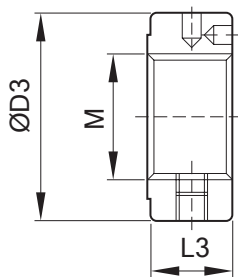

BK 型

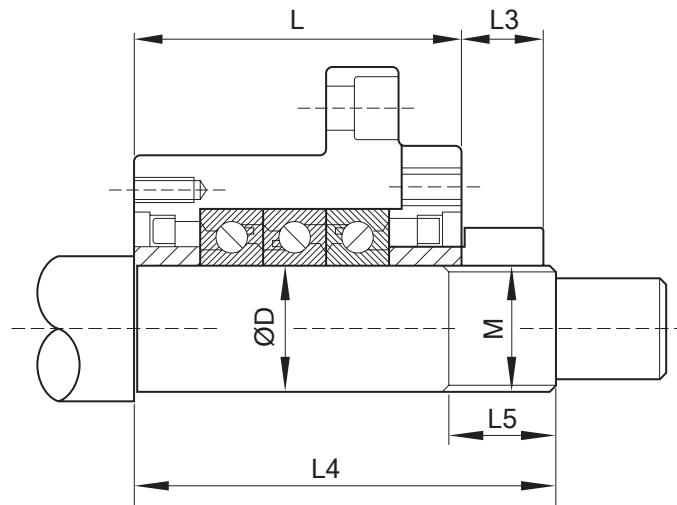

BK 型

單位/Unit : mm

型號	使用軸承	基本動定格荷重 Ca(N)	界限荷重 N	預壓荷重 N	軸方向剛性 N/um	起動力距 N-cm	鎖固螺帽 Lock nut			重量 Kgs	軸端尺寸		
							M	D3	L3		d	L4	L5
WBK 17DF	17TAC47 P4	21900	26600	2150	750	14.0	M17 x 1	37	18	1.9	17	81	23
WBK 20DF	20TAC47 P4	21900	26600	2150	750	14.0	M20 x 1	40	18	1.9	20	81	23
WBK 25DF	25TAC62 P4	28500	40500	3150	1000	23.0	M25 x 1.5	45	20	3.1	25	89	26
WBK 25DF	25TAC62 P4	46500	81500	4300	1470	31.0	M25 x 1.5	45	20	3.4	25	104	26
WBK 30DF	30TAC62 P4	29200	43000	3350	1030	24.0	M30 x 1.5	50	20	3.0	30	89	26
WBK 30DF	30TAC62 P4	47500	86000	4500	1520	33.0	M30 x 1.5	50	20	3.3	30	104	26
WBK 35DF	35TAC72 P4	31000	50000	3800	1180	28.0	M35 x 1.5	55	22	3.4	35	92	30
WBK 35DF	35TAC72 P4	50500	100000	5200	1710	37.0	M35 x 1.5	55	22	4.3	35	107	30
WBK 40DF	40TAC72 P4	31500	52000	3900	1230	28.0	M40 x 1.5	60	22	3.6	40	92	30
WBK 40DF	40TAC72 P4	51500	104000	5300	1810	38.0	M40 x 1.5	60	22	4.2	40	107	30

■ 鎖固螺帽

訂購編號 Order Coding	型號 Model No.	表面處理 Surface treatment	鎖緊扭矩 kgf-cm
RN05	M5 x P0.5	染黑 Black Oxide	
RN05_N		化學鍍 Electyless Nickel Plating	
RN06	M6 x P0.75	染黑 Black Oxide	25
RN06_N		化學鍍 Electyless Nickel Plating	
RN08	M8 x P1.0	染黑 Black Oxide	50
RN08_N		化學鍍 Electyless Nickel Plating	
RN10	M10 x P1.0	染黑 Black Oxide	95
RN10_N		化學鍍 Electyless Nickel Plating	
RN12	M12 x P1.0	染黑 Black Oxide	140
RN12_N		化學鍍 Electyless Nickel Plating	
RN15	M15 x P1.0	染黑 Black Oxide	240
RN15_N		化學鍍 Electyless Nickel Plating	
RN17	M17 x P1.0	染黑 Black Oxide	
RN17_N		化學鍍 Electyless Nickel Plating	
RN17W	M17 x P1.0 (WBK17-31用)	染黑 Black Oxide	550
RN17W_N		化學鍍 Electyless Nickel Plating	
RN20	M20 x P1.0	染黑 Black Oxide	480
RN20_N		化學鍍 Electyless Nickel Plating	
RN20W	M20 x P1.0 (WBK20-31用)	染黑 Black Oxide	750
RN20W_N		化學鍍 Electyless Nickel Plating	
RN25	M25 x P1.5	染黑 Black Oxide	860
RN25_N		化學鍍 Electyless Nickel Plating	
RN25W	M25 x P1.5 (WBK25-31用)	染黑 Black Oxide	1350
RN25W_N		化學鍍 Electyless Nickel Plating	
RN30	M30 x P1.5	染黑 Black Oxide	
RN30_N		化學鍍 Electyless Nickel Plating	
RN30W	M30 x P1.5 (WBK30-31用)	染黑 Black Oxide	2000
RN30W_N		化學鍍 Electyless Nickel Plating	
RN35	M35 x P1.5	染黑 Black Oxide	
RN35_N		化學鍍 Electyless Nickel Plating	
RN35W	M35 x P1.5 (WBK35-31用)	染黑 Black Oxide	3000
RN35W_N		化學鍍 Electyless Nickel Plating	
RN40	M40 x P1.5	染黑 Black Oxide	
RN40_N		化學鍍 Electyless Nickel Plating	
RN40W	M40 x P1.5 (WBK40-31用)	染黑 Black Oxide	4000
RN40W_N		化學鍍 Electyless Nickel Plating	



染黑 (適用環境一般)



化學鍍 (適用無塵室環境)



染黑 (適用環境一般)

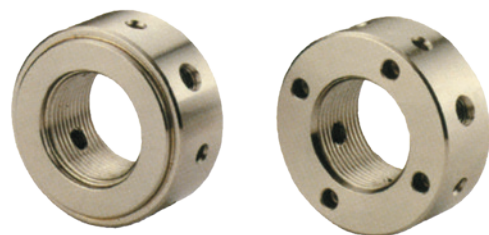

化學鍍 (適用無塵室環境)

TYPE OF SUPPORT UNITS AND APPLICABLE BALL SCREW DIAMETERS

■ 螺桿支撐座適用滾珠螺桿外徑

固定側支撐座 內徑 (mm)	固定側支撐座 適用型號	支撐側支撐座 內徑 (mm)	支撐側支撐座 適用型號	適用滾珠螺桿 外徑 (mm)
5	EK05	-	-	Ø6
	FK05			
6	EK06	6	EF06	Ø8
	FK06		FF06	
8	EK08	6	EF08	Ø10
	FK08		FF08	
10	EK10	8	EF10	Ø10, Ø12, Ø14
	FK10		FF10	
	BK10		BF10	
	AK10		AF10	
12	EK12	10	EF12	Ø14, Ø15, Ø16
	FK12		FF12	
	BK12		BF12	
	AK12		AF12	
15	EK15	15	EF15	Ø20
	FK15		FF15	
	BK15		BF15	
	AK15		AF15	
17	BK17	17	BF17	Ø20, Ø25
	FK17		FF17	
20	EK20	20	EF20	Ø25, Ø28
	FK20		FF20	
	BK20		BF20	
	AK20		AF20	
25	FK25	25	FF25	Ø32, Ø36
	BK25		BF25	
30	FK30	30	FF30	Ø40, Ø45
	BK30		BF30	
35	BK35	35	BF35	Ø45
40	BK40	40	BF40	Ø50

REFERENCE OF AXIAL LOAD OF FIXED-SIDE TYPE SUPPORT UNITS

■ 螺桿支撐座固定端軸向負荷參考表

支撐座型號		軸承	靜負荷 (kgf)	軸向負荷 (kgf)	極限轉速 (RPM)
FK06	EK06	706	106	53	-
FK08	EK08	708	148	74	-
BK10	AK10	7000A	266	133	16800
FK10	EK10				
BK12	AK12	7001A	305	153	15400
FK12	EK12				
BK15	AK15	7002A	350	175	13300
FK15	EK15				
BK17	FK17	7203A	610	305	11200
		7203B	565	363	7700
BK20		7004A	670	335	10500
FK20	AK20	7204A	845	423	9100
	EK20	7204B	780	501	6650
BK25	FK25	7205A	1050	525	8400
		7205B	960	617	5950
BK30	FK30	7206A	1510	755	7000
		7206B	1380	887	4970
BK35		7207B	1870	1202	4200
BK40		7208B	2340	1504	3710

■ 建議軸端加工尺寸(固定側)

BK型

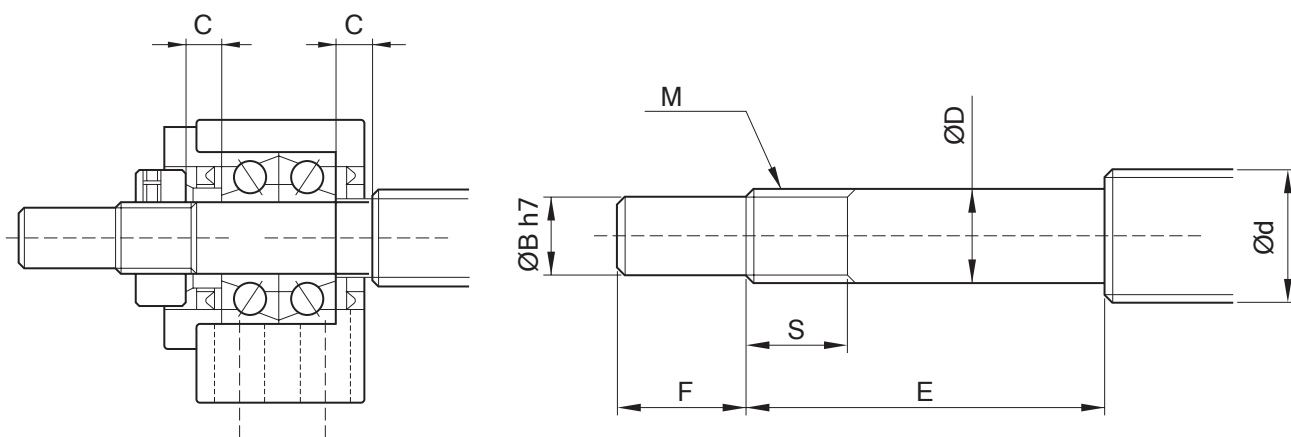

BK 型

單位/Unit : mm

型號	滾珠螺桿軸外徑	軸端部外徑	公稱螺紋			套銅長度		
BK 型	d	D	B	E	F	M	S	C
BK10	12/14/15	10 -0.005 -0.012	8	36	15	M10 x 1	16	5.5
BK12	14/15/16	12 -0.005 -0.012	10	36	15	M12 x 1	14	5.5
BK15	18/20	15 -0.005 -0.014	12	40	20	M15 x 1	12	6
BK17	20/25	17 -0.005 -0.014	15	53	23	M17 x 1	17	7
BK20	25/28	20 -0.005 -0.014	17	53	25	M20 x 1	15	8
BK25	32/36	25 -0.005 -0.014	20	65	30	M25 x 1.5	18	9
BK30	36/40	30 -0.005 -0.015	25	72	38	M30 x 1.5	25	9
BK35	45	35 -0.005 -0.015	30	81	45	M35 x 1.5	28	12
BK40	50	40 -0.005 -0.015	35	93	50	M40 x 1.5	35	15

■ 建議軸端加工尺寸(固定側)

FK, EK, AK 型

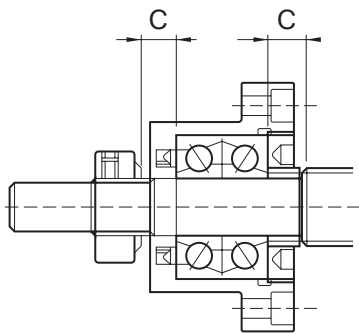
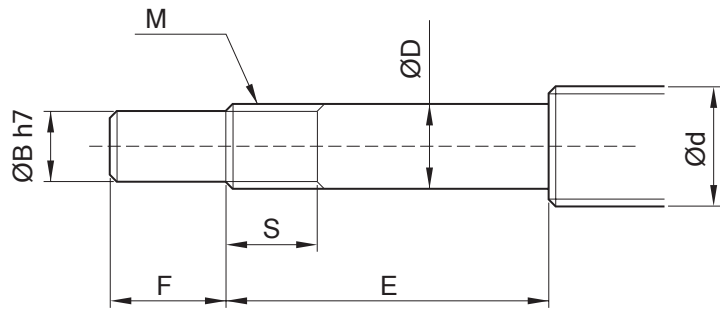

FK 型

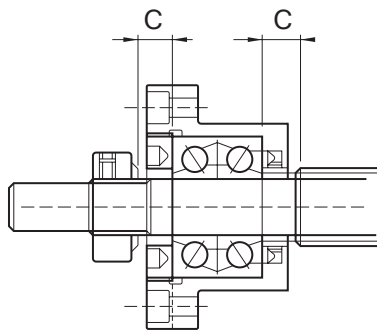

FK 型

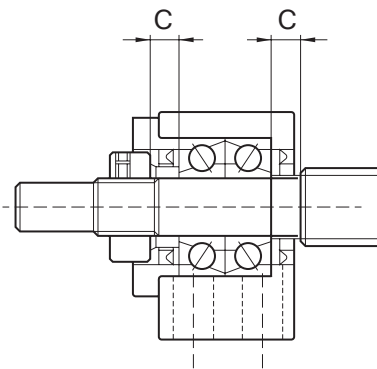

EK, AK 型

單位/Unit : mm

型	號	滾珠螺桿軸外徑	軸端部外徑				公稱螺紋	套銅長度		
FK 型	EK 型	AK 型	d	D	B	E	F	M	S	C
FK05	EK05	-	8	5 ^{-0.005} -0.012	4	25	6	M5 x 0.5	7	3.5
FK06	EK06	-	8	6 ^{-0.005} -0.012	4	28	8	M6 x 0.75	8	5
FK08	EK08	-	10/12	8 ^{-0.005} -0.012	6	32	9	M8 x 1	10	5.5
FK10	EK10	AK10	12/14/15	10 ^{-0.005} -0.012	8	36	15	M10 x 1	11	5.5
FK12	EK12	AK12	14/15/16	12 ^{-0.005} -0.012	10	36	15	M12 x 1	11	5.5
FK15	EK15	AK15	18/20	15 ^{-0.005} -0.014	12	40	20	M15 x 1	13	10
FK17	-	-	20/25	17 ^{-0.005} -0.014	15	53	23	M17 x 1	15	10
FK20	EK20	AK20	25/28	20 ^{-0.005} -0.014	17	53	25	M20 x 1	17	11
FK25	-	-	32/36	25 ^{-0.005} -0.014	20	65	30	M25 x 1.5	20	15
FK30	-	-	36/40	30 ^{-0.005} -0.015	25	72	38	M30 x 1.5	25	9

■ 建議軸端加工尺寸(固定側)

FF,EF,BF,AF 型

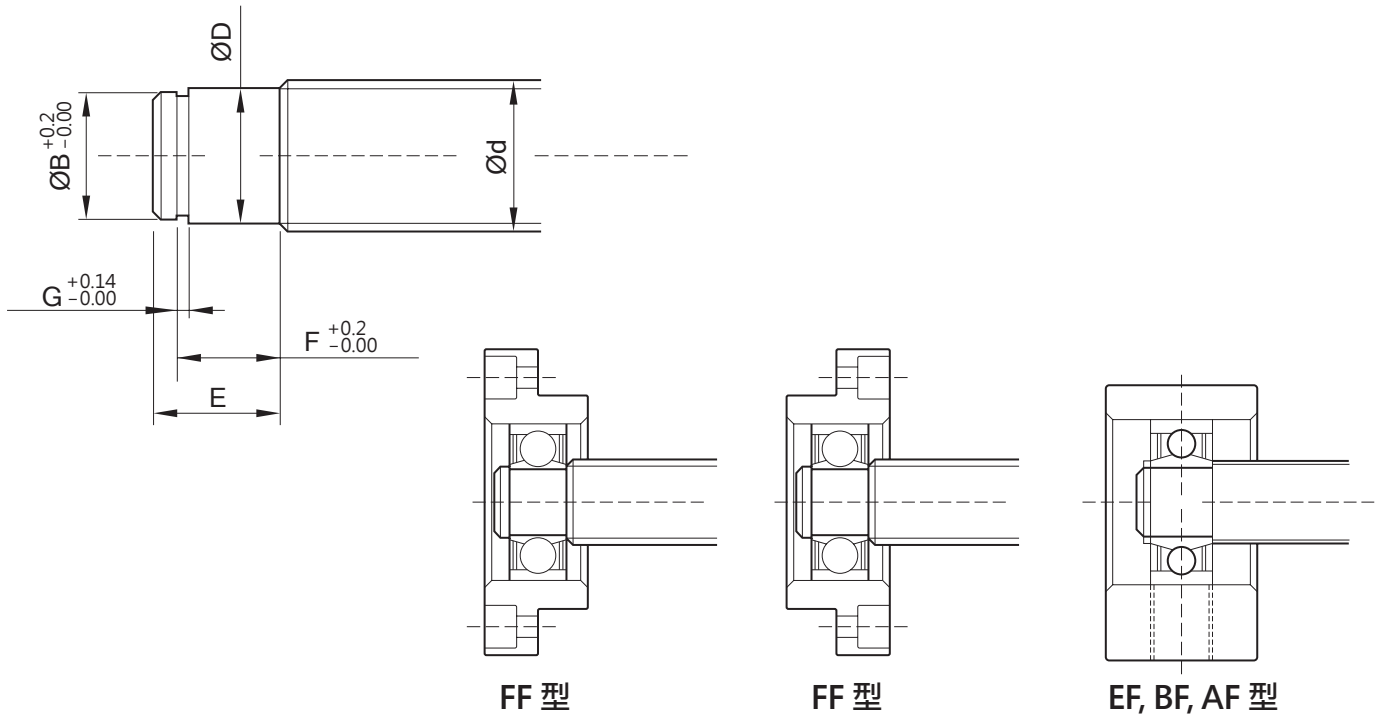

單位/Unit : mm

型				號	滾珠螺桿軸外徑	軸端部外徑				
FF 型	EF 型	BF 型	AF 型		d	D	E	B	F	G
FF06	EF06	-	-		8	6 ^{-0.005/-0.012}	9	5.7	6.8	0.8
-	EF08	-	-		10	6 ^{-0.005/-0.012}	9	5.7	6.8	0.8
FF10	EF10	BF10	AF10		12/14/15	8 ^{-0.005/-0.012}	10	7.6	7.9	0.9
FF12	EF12	BF12	AF12		14/15/16	10 ^{-0.005/-0.012}	11	9.6	9.15	1.15
FF15	EF15	BF15	AF15		18/20	15 ^{-0.005/-0.014}	13	14.3	10.15	1.15
FF17	-	BF17	-		20/25	17 ^{-0.005/-0.014}	16	16.2	13.15	1.15
FF20	EF20	BF20*	AF20		25/28/30	20 ^{-0.005/-0.014}	19(16)	19	15.35(13.35)	1.35
FF25	-	BF25	-		30/32/36	25 ^{-0.005/-0.014}	20	23.9	16.35	1.35
FF30	-	BF30	-		36/40	30 ^{-0.005/-0.015}	21	28.6	17.75	1.75
-	-	BF35	-		40/45	35 ^{-0.005/-0.015}	22	33	18.75	1.75
-	-	BF40	-		50	40 ^{-0.005/-0.015}	23	38	19.75	1.95

■ 螺桿支撐座各廠牌型號對照表

螺桿支撐座系列

BALLSCREW SUPPORT UNITS EQUIVALENT INTERCHANGEABLE FOR MAJOR MANUFACTURER

SYK & THK	SYK & THK	KURODA	NSK	SYK & THK	KURODA	NSK
BK10	EK05	-	-	FK05	-	-
BK12	EK06	BUR-6	WBK06-01A	FK06	-	WBK06-11
BK15	EK08	BUR-8	WBK08-01A	FK08	BUM-08	WBK08-11
BK17	EK10	-	-	FK10	BUM-10	WBK10-11
BK20	EK12	-	-	FK12	BUM-12	WBK12-11
BK25	EK15	-	-	FK15	BUM-15	WBK15-11
BK30	EK20	-	-	FK17	-	-
BK35				FK20	BUM-20	WBK20-11
BK40				FK25	BUM-25	WBK25-11
	EF06	-	-	FK30	-	-
	EF08	BUK-6S	WBK08S-01			
	EF10	-	-	FF06	-	-
BF10	EF12	-	-	FF10	-	-
BF12	EF15	-	-	FF12	-	-
BF15	EF20	-	-	FF15	-	-
BF17				FF17	-	-
BF20	SYK & THK	KURODA	NSK	FF20	-	-
BF25	AK10	BUK-10F	WBK10-01A	FF25	-	-
BF30	AK12	BUK-12F	WBK12-01A	FF30	-	-
BF35	AK15	BUK-15F	WBK15-01A			
BF40	AK17	-	WBK17-01A			
	AK20	BUK-20F	WBK20-01A			
	-	BUK-25F	WBK25-01A			
	AF10	BUK-8S	WBK10S-01			
	AF12	BUK-10S	WBK12S-01			
	AF15	BUK-15S	WBK15S-01			
	AF17	-	WBK17S-01			
	AF20	BUK-20S	WBK20S-01			
	-	BUK-25S	WBK25S-01			