

軸承鋼軸心

■ SF ※※

表面鍍鉻軸心

材質：軸承鋼(SUJ2)

處理：高周波熱處理及研磨

硬度：HRC62 ±2

產品型號

SF25

X

500L

軸外徑 \varnothing 25mm

軸全長 500mm

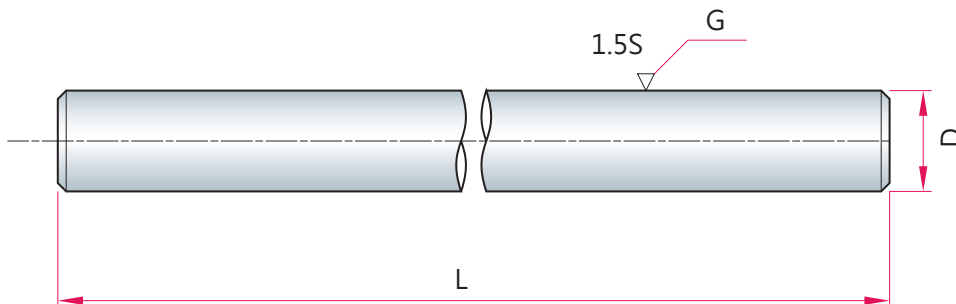
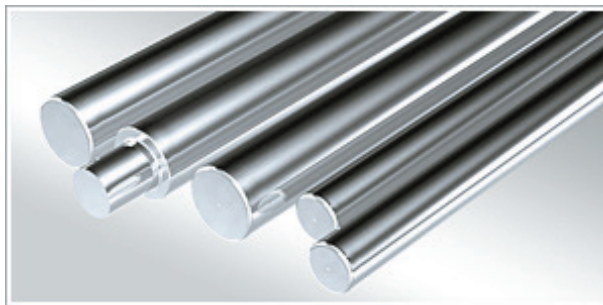

單位 UNIT : mm

外徑 D mm	型號 SFR	外徑公差 $\mu\text{m g6}$	最大製作長度 L mm	有效硬化層深度 mm	重量 kg/m	適用軸承型號	
3	SF 3	-4 -12	400	1.5 以上	0.06	LM 3	
4	SF 4		400		0.10	LM 4	
5	SF 5		2000		0.16	LM 5	
6	SF 6	3000	0.23		LM 6		
8	SF 8	-5	3000		0.40	LM 8	
10	SF 10	-14	4000		0.62	LM 10	
12	SF 12	-6 -17	6000		2.0 以上	0.89	LM 12
13	SF 13		6000			1.05	LM 13
16	SF 16		6000			1.58	LM 16
20	SF 20	-7 -20	6000			2.47	LM 20
25	SF 25		6000	3.85		LM 25	
30	SF 30		6000	5.55		LM 30	
35	SF 35	-9 -25	6000	2.5 以上	7.55	LM 35	
40	SF 40		6000		9.87	LM 40	
50	SF 50		6000		15.41	LM 50	
60	SF 60	-10 -29	6000	3.0 以上	22.20	LM 60	
80	SF 80		6000		39.46	LM 80	
100	SF 100		6000		61.66	LM 100	
		-12 -34					

精密軸心系列

■ SCF ※※

不生鏽軸心

材質：軸承鋼(SUJ2)

處理：高周波熱處理及研磨, 表層鍍硬鉻

硬度：HRC62 ±2

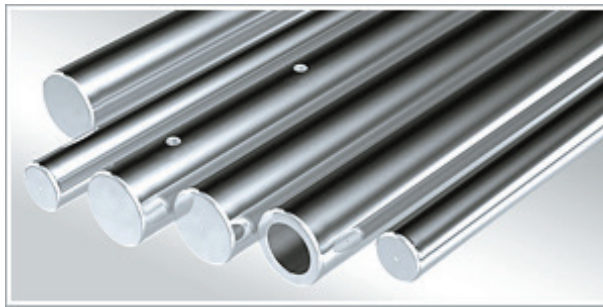

產品型號

SCF25 X **500L**
軸外徑 \varnothing 25mm 軸全長 500mm

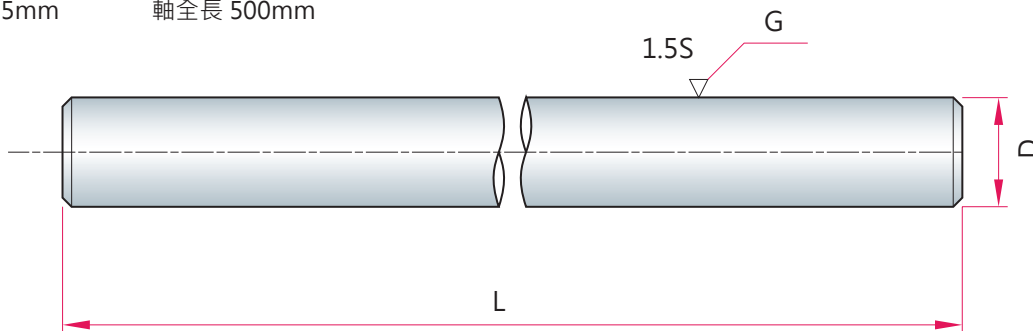

單位 UNIT : mm

外徑 D mm	型號 SFR	外徑公差 $\mu\text{m g6}$	最大製作長度 L mm	有效硬化層深度 mm	重量 kg/m	適用軸承型號
3	SCF 3	-4 -12	400	1.5 以上	0.06	LM 3
4	SCF 4		400		0.10	LM 4
5	SCF 5		2000		0.16	LM 5
6	SCF 6		3000		0.23	LM 6
8	SCF 8	-5	3000		0.40	LM 8
10	SCF 10	-14	4000		0.62	LM 10
12	SCF 12	-6 -17	6000	2.0 以上	0.89	LM 12
13	SCF 13		6000		1.05	LM 13
16	SCF 16	6000	2.5 以上		1.58	LM 16
20	SCF 20	-7 -20		6000	2.47	LM 20
25	SCF 25			6000	3.85	LM 25
30	SCF 30	6000		3.0 以上	5.55	LM 30
35	SCF 35	-9 -25	6000		7.55	LM 35
40	SCF 40		6000		9.87	LM 40
50	SCF 50	-10 -29	6000	61.66	15.41	LM 50
60	SCF 60		6000		22.20	LM 60
80	SCF 80		6000		39.46	LM 80
100	SCF 100	-12 -34	6000		61.66	LM 100

精密軸心系列

■ SCFH ※※

管狀軸心 (空心軸)

材質：軸承鋼(SUJ2)

硬度：HRC62 ±2

表面粗度：0.4Ra以下

產品型號

SNT25

X

500L

軸外徑 \varnothing 25mm

軸全長 500mm

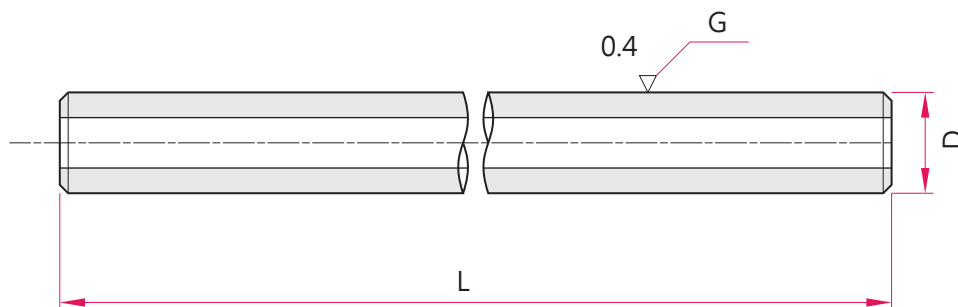
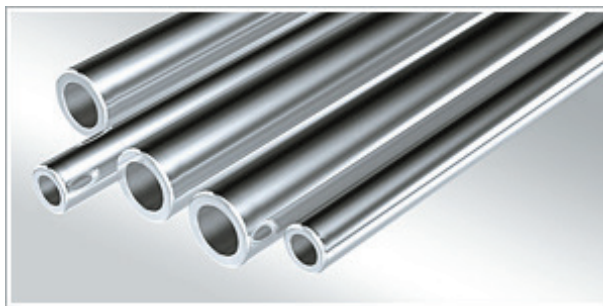

單位 UNIT : mm

外徑 D mm	內徑 d mm	型號 SNT	外徑公差 $\mu\text{m h6}$	最大製作長度 L mm	有效硬化層深度 mm	重量 kg/m	外徑 D mm
10	4	SNT 10	0 ~ -9	1000	1.2	0.52	10
12	4	SNT 12	0 ~ -11	2000	1.3	0.79	12
13	5	SNT 13	0 ~ -11	2000	1.3	0.82	13
16	7	SNT 16	0 ~ -11	4000	1.6	1.28	16
20	14	SNT 20	0 ~ -13	5000	1.8	1.25	20
25	15.6	SNT 25	0 ~ -13	5000	2.0	2.35	25
30	18.3	SNT 30	0 ~ -13	6000	2.4	3.50	30
35	22	SNT 35	0 ~ -16	6000	2.5	4.90	35
40	28	SNT 40	0 ~ -16	6000	2.6	4.99	40
50	29.7	SNT 50	0 ~ -16	6000	2.9	9.91	50
60	36	SNT 60	0 ~ -19	6000	3.0	14.20	60
80	57	SNT 80	0 ~ -19	6000	3.2	19.43	80
100	65	SNT 100	0 ~ -22	6000	3.3	35.61	100

軸心支持座 SH 系列

■ SH ※※ A

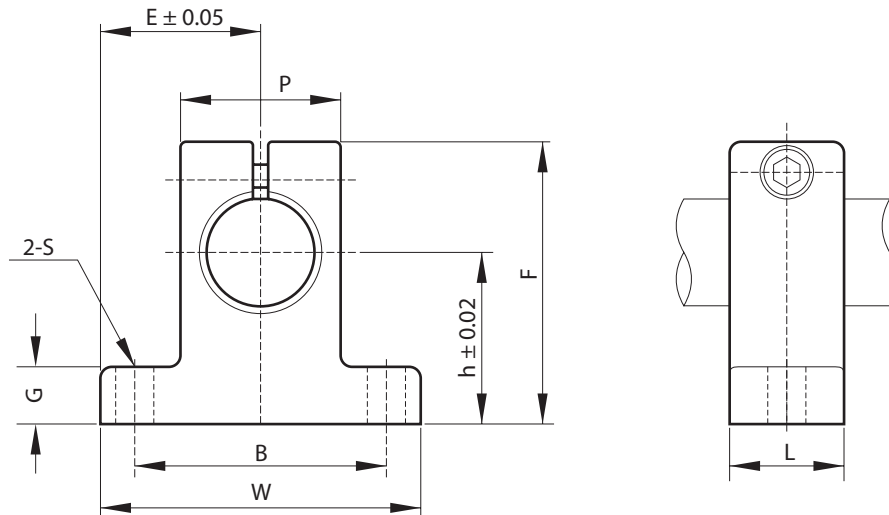

型號 MODEL NO	軸徑 SHAFT DIAMETER	主要尺寸 MAIN DIMENSIONS									鎖緊螺栓 DESIGNATION OF CLAMPING BLOT	安裝螺栓 DESIGNATION OF MOUNTING BLOT	重量 WEIGHT (g)
		H	E	W	L	F	G	P	B	S			
SH08	8	20	21	42	14	32.8	6	18	32	5.5	M4	M5	24
SH10	10	20	21	42	14	32.8	6	18	32	5.5	M4	M5	24
SH12	12	23	21	42	14	37.5	6	20	32	5.5	M4	M5	30
SH13	13	23	21	42	14	37.5	6	20	32	5.5	M4	M5	30
SH16	16	27	24	48	16	44	8	25	38	5.5	M4	M5	40
SH20	20	31	30	60	20	51	10	30	45	6.6	M5	M6	70
SH25	25	35	35	70	24	60	12	38	56	6.6	M6	M6	130
SH30	30	42	42	84	28	70	12	44	64	9	M6	M8	180
SH35	35	50	49	98	32	82	15	50	74	11	M8	M10	270
SH40	40	60	57	114	36	96	15	60	90	11	M8	M10	420
SH50	50	70	63	126	40	120	18	74	100	14	M12	M12	750
SH60	60	80	74	148	45	136	18	90	120	14	M12	M12	1100

軸心支持座 SHF 系列

■ SHF ※※

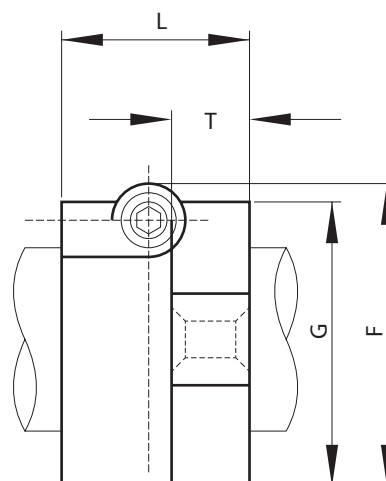
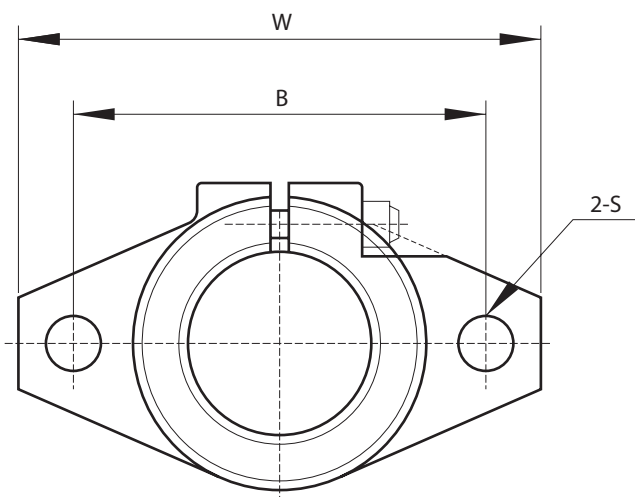

型號 MODEL NO	軸徑 SHAFT DIAMETER	主要尺寸 MAIN DIMENSIONS							鎖緊螺栓 DESIGNATION OF CLAMPING BLOT	安裝螺栓 DESIGNATION OF MOUNTING BLOT	重量 WEIGHT (g)
		W	L	T	F	G	B	S			
SHF10	10	43	10	5	24	20	32	5.5	M4	M5	13
SHF12	12	47	13	7	28	25	36	5.5	M4	M5	20
SHF13	13	47	13	7	28	25	36	5.5	M4	M5	20
SHF16	16	50	16	8	31	28	40	5.5	M4	M5	27
SHF20	20	60	20	8	37	34	48	7	M5	M6	40
SHF25	25	70	25	10	42	40	56	7	M6	M6	60
SHF30	30	80	30	12	50	46	64	9	M6	M8	110
SHF35	35	92	35	14	58	50	72	12	M8	M10	380
SHF40	40	102	40	16	67	56	80	12	M10	M10	510
SHF50	50	122	50	19	83	70	96	14	M12	M12	890
SHF60	60	140	60	23	95	82	112	14	M12	M12	1500

軸心支持座 SA 系列

亞洲泛用公制
ASIA SERIES

■ SA ※※

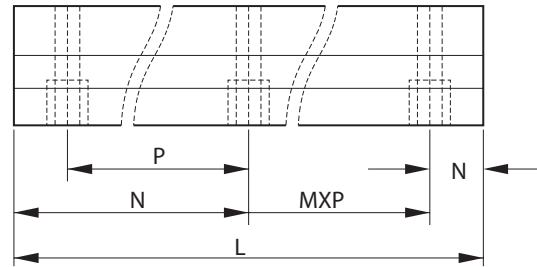
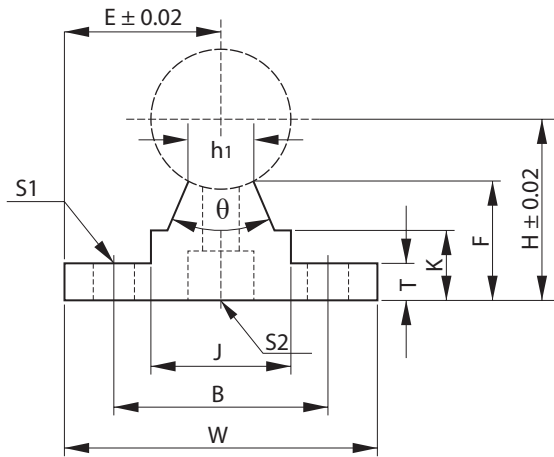

型號 MODEL NO	軸徑 SHAFT DIAMETER	主要尺寸 MAIN DIMENSIONS										安裝螺栓 MOUNTING DIMENSIONS					重量 WEIGHT (g)	
		H	E	W	L	F	T	K	J	h1	θ	B	N	M X P	S1	S2		
SA10-200	10	18	16	32	200	13.5	4	8.9	12.4	4.7	80°	22	50	1 X 100	4.5	M4	0.110	
SA10-300					300								50	2 X 100				0.160
SA10-400					400								50	3 X 100				0.220
SA10-500					500								50	4 X 100				0.270
SA10-600					600								50	5 X 100				0.330
SA12-200	12	20.46	17	34	200	15	4.5	9.8	15	6	80°	25	50	1 X 100	4.5	M4	0.140	
SA12-300					300								50	2 X 100				0.210
SA12-400					400								50	3 X 100				0.280
SA12-500					500								50	4 X 100				0.350
SA12-600					600								50	5 X 100				0.420
SA13-200	13	21	17	34	200	15	4.5	9.8	15	6	80°	25	50	1 X 100	5.5	M4	0.140	
SA13-300					300								50	2 X 100				0.210
SA13-400					400								50	3 X 100				0.280
SA13-500					500								50	4 X 100				0.350
SA13-600					600								50	5 X 100				0.420
SA16-200	16	25	20	40	200	17.8	5	11.7	18.5	8	80°	30	25	1 X 150	5.5	M5	0.200	
SA16-300					300								75	1 X 150				0.300
SA16-400					400								50	2 X 150				0.400
SA16-500					500								25	3 X 150				0.500
SA16-600					600								75	3 X 150				0.600
SA20-200	20	27	22.5	45	200	17.7	5	10	19	8	50°	30	25	1 X 150	5.5	M6	0.200	
SA20-300					300								75	1 X 150				0.300
SA20-400					400								50	2 X 150				0.400
SA20-500					500								25	3 X 150				0.510
SA20-600					600								75	3 X 150				0.610
SA25-200	25	33	27.5	55	200	21	6	12	21.5	8	50°	35	25	1 X 150	6.5	M6	0.290	
SA25-300					300								50	1 X 200				0.430
SA25-400					400								100	1 X 200				0.580
SA25-500					500								50	2 X 200				0.730
SA25-600					600								100	2 X 200				0.880

軸心支持座 SA 系列

■ SA ※※

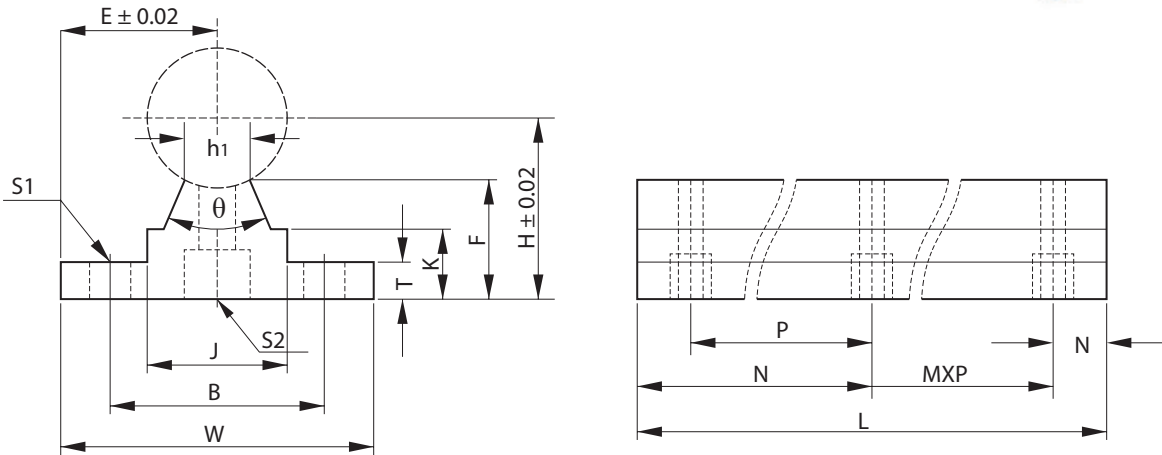

型號 MODEL NO	軸徑 SHAFT DIAMETER	主要尺寸 MAIN DIMENSIONS										安裝螺栓 MOUNTING DIMENSIONS					重量 WEIGHT (g)	
		H	E	W	L	F	T	K	J	h1	θ	B	N	M X P	S1	S2		
SA30-200	30	37	30	60	200	22.8	7	13	26.5	10.3	50°	40	25	1 X 150	6.5	M8	0.360	
SA30-300					300								50	1 X 200				0.550
SA30-400					400								100	1 X 200				0.730
SA30-500					500								50	2 X 200				0.920
SA30-600					600								100	2 X 200				1.100
SA35-200	35	43	32.5	65	200	26.5	8	15.5	28	13	50°	45	25	1 X 150	9	M8	0.460	
SA35-300					300								50	1 X 200				0.700
SA35-400					400								100	1 X 200				0.950
SA35-500					500								50	2 X 200				1.190
SA35-600					600								100	2 X 200				1.420
SA40-200	40	48	37.5	75	200	29.4	9	17	38	15.5	50°	55	25	1 X 150	9	M8	0.630	
SA40-300					300								75	1 X 150				0.960
SA40-400					400								50	1 X 300				1.290
SA40-500					500								100	1 X 300				1.610
SA40-600					600								150	1 X 300				1.950
SA50-200	50	62	47.5	95	200	38.8	11	21	45	20	50°	70	25	1 X 150	11	M10	1.000	
SA50-300					300								75	1 X 150				1.500
SA50-400					400								50	1 X 300				2.000
SA50-500					500								100	1 X 300				2.500
SA50-600					600								150	1 X 300				3.000

精密軸心系列

■ SCFT ※※

外徑基線攻牙軸心

材質：軸承鋼(SUJ2)

硬度：HRC62 ±2

表面粗度：0.4Ra以下

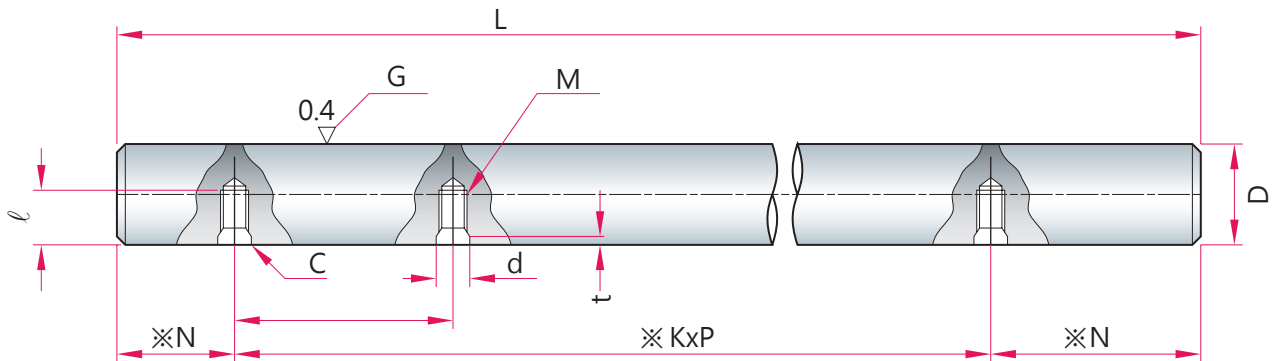

$$\text{※ N: } \frac{L - K \times P}{2}$$

※ K: 間距個數

單位 UNIT : mm

外徑 D mm	型號		外徑公差 μm g6	孔距 P	螺柱 M	螺牙深度 l	沉窩孔 d	沉窩孔深 t	倒角 C	最大長度 L max
16	SFB16	SFRB16	-6 ~ -17	150	M5 X 0.8	9	5.5	2.5	0.7	4000
20	SFB20	SFRB20	-7 ~ -20	150	M6 X 1	10	6.5	2.5	0.7	6000
25	SFB25	SFRB25	-7 ~ -20	200	M6 X 1	12	6.5	2.5	0.7	6000
30	SFB30	SFRB30	-7 ~ -20	200	M8 X 1.25	15	8.5	3.0	1	6000
35	SFB35	SFRB35	-9 ~ -25	200	M8 X 1.25	15	8.5	3.0	1	6000
40	SFB40	SFRB40	-9 ~ -25	300	M8 X 1.25	18	8.5	3.0	1	6000

軸心加工規範

代客加工各種尺寸規範

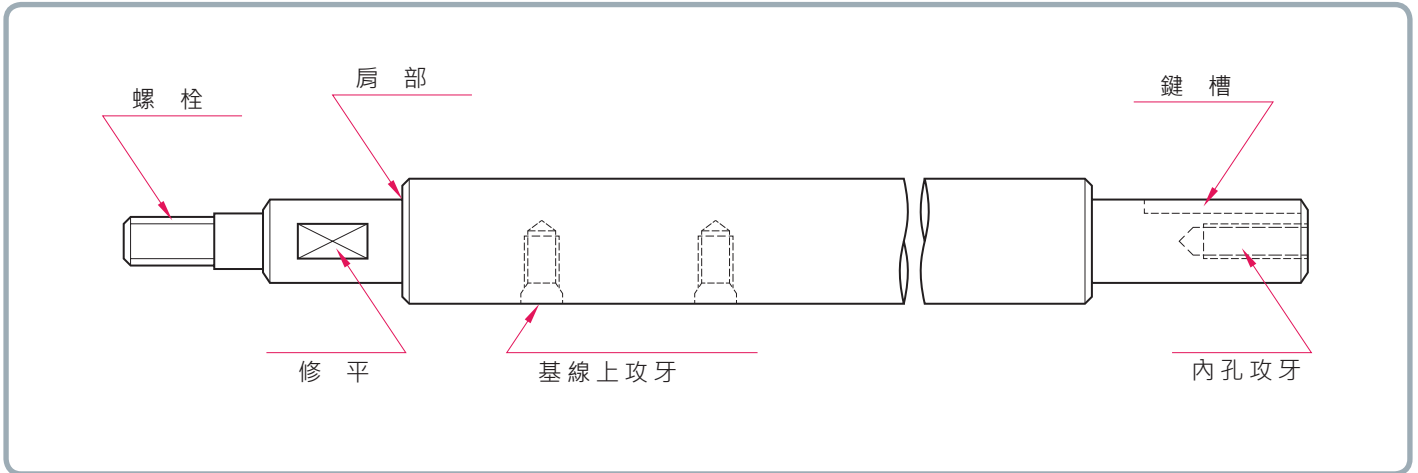

單位 UNIT : mm

